

DESIGN, CONSTRUCTION, AND TESTING  
OF AN ALMOND HARVESTER PICK-UP BELT  
TENSIONING MECHANISM

Brandon Eller

BioResource and Agricultural Engineering Department

California Polytechnic State University

San Luis Obispo

2012

TITLE: Design, Construction, and Testing of an Almond Harvester  
Pick-Up Belt Tensioning Mechanism

AUTHOR: Brandon Eller

DATE SUBMITTED: Spring 2012

Mark A. Zohns  
Senior Project Advisor

\_\_\_\_\_  
Signature

\_\_\_\_\_  
Date

Richard A. Cavaletto  
Department Head

\_\_\_\_\_  
Signature

\_\_\_\_\_  
Date

## **ACKNOWLEDGMENTS**

I would like to acknowledge and sincerely thank the excellent faculty and staff in the BRAE department for their assistance and guidance during this project. I would like to especially thank Dr. Mark Zohns for directly advising me on this project. Also, a special thanks to Dr. Andrew Holtz for his input and additional direction. Finally, this project would have been much more difficult without the excellent support and technical knowledge from lab technician Virgil Threlkel. My education has greatly benefited from the instruction from these excellent instructors.

Secondly I would like to thank Flory Industries for their sponsorship of this project. Information from them was invaluable to the research process. Also, having the ability to have parts fabricated through them was a big help. Finally, the technical advice from the service and engineering departments was critical to the success of this project.

Finally I would like to thank my family for their support as I attended Cal Poly, and especially my wife, Kalie, as she allowed me to spend the time necessary to complete this project and complete my engineering degree.

## **ABSTRACT**

This senior project presents the design, fabrication, and testing of a tensioning mechanism for an almond harvester pick-up belt system. This tensioner was intended to reduce belt tension spikes when obstructions are encountered in the system, and was tested on a previously fabricated pick-up belt test stand. The result of this project is a prototype tensioner mechanism that was tested with favorable results. Also, the project includes a results and discussion section that presents an improved design based on the testing results.

## **DISCLAIMER STATEMENT**

The university makes it clear that the information forwarded herewith is a project resulting from a class assignment and has been graded and accepted only as a fulfillment of a course requirement. Acceptance by the university does not imply technical accuracy or reliability. Any use of the information in this report is made by the user at his/her own risk, which may include catastrophic failure of the device or infringement of a patent or copyright law.

Therefore, the recipient and/or user of the information contained in this report agrees to indemnify, defend, and save harmless the State, its officers, agents, and employees from any and all claims and losses accruing or resulting to any person, firm, or corporation who may be injured or damaged as a result of the use of this report and equipment.

# TABLE OF CONTENTS

ACKNOWLEDGMENTS .....	iii
ABSTRACT .....	iv
DISCLAIMER STATEMENT .....	v
TABLE OF CONTENTS.....	vi
LIST OF FIGURES .....	viii
INTRODUCTION .....	1
Background.....	1
Justification.....	1
LITERATURE REVIEW .....	4
Mechanical Springs.....	4
Gas Springs .....	5
Hydraulic System.....	6
Direct Acting Reducing Valve.....	7
Pilot Operated Reducing Valve. ....	8
Pick-Up Belt Details .....	9
PROCEDURES AND METHODS.....	11
Design Procedure .....	11
Design Constraints.....	11
Initial Design.....	12
Design Calculations. ....	15
Fabrication .....	18
Fab Parts from Flory Industries. ....	18
Fabrication of Remaining Parts. ....	19
Buyout Parts.....	21
Testing.....	22
Pressure Testing / Range of Motion.....	22
Dynamic Testing.....	23

RESULTS AND DISCUSSION .....	25
Testing Results.....	25
Revised Design .....	25
Belt Tester Recommendations .....	28
Manual Tensioner System Testing.....	29
Belt Tracking Concerns with Tensioner .....	31
Belt Guidance Possibilities .....	31
Final Conclusion .....	33
REFERENCES .....	34
APPENDIX A.....	35
HOW PROJECT MEETS REQUIREMENTS FOR THE BRAE MAJOR .....	35
Major Design Experience .....	36
Capstone Design Experience .....	36
Design Parameters and Constraints .....	37
APPENDIX B .....	38
DESIGN CALCULATIONS .....	38
Design Belt Tension Specification.....	39
Cylinder Sizing .....	40
Belt Stretch Calculation .....	41
Fluid Flow during Deflection.....	43
Fluid Velocity during Deflection .....	44
Spring Solid Safe Calculation.....	45
Upper Cylinder Mount Weld Analysis .....	46
Cylinder Mount Bolt Shear.....	47
Upper Adjuster Plate FEA Analysis .....	48
Adjuster Bolt Torque and Force Theoretical Relationship.....	49
APPENDIX C .....	50
CONSTRUCTION DRAWINGS .....	50

## LIST OF FIGURES

Figure 1. Flory 850 Almond Harvester Schematic (Flory Industries, 2012).....	1
Figure 2. Pick-up Belt Mounted in Tester. ....	2
Figure 3. Manual Belt Tension System.....	3
Figure 4. Pick-up Belt Tester. ....	3
Figure 5. Linear Spring Example (4physics, 2012). ....	4
Figure 6. Coiled Constant Tension Spring (Vulcan Springs, 2012). ....	5
Figure 7. Cutaway Diagram of a Typical Gas Spring (Titan, 2012).....	6
Figure 8. Direct Acting Pressure Reducing Valve (Eaton, 2008).....	7
Figure 9. Pilot Operated Reducing Valve (Eaton, 2008).....	8
Figure 10. Pick-Up Belt Model in SolidWorks. ....	9
Figure 11. Belt Joint Detail.....	10
Figure 12. Upper Roller Shaft.....	11
Figure 13. Lower Roller Shaft. ....	12
Figure 14. Hydraulic Tensioner Design.....	13
Figure 15. Spring Tensioner Mechanism.....	14
Figure 16. Factor of Safety Plot for Upper Cylinder Mount.....	16
Figure 17. FOS Plot for Lower Bearing Mount and Cylinder Mount. ....	17
Figure 18. Upper Mount. ....	18
Figure 19. Lower Mount. ....	19
Figure 20. Machining the UHMW Bushings with the Lathe.....	20
Figure 21. Timken 1.5” Flange Bearing. ....	21
Figure 22. The Completed Prototype Hydraulic Tensioner.....	22
Figure 23. BRAE Hydraulic Power Pack. ....	23
Figure 24. Revised Hydraulic Design.....	26
Figure 25. Upper Adjuster Detail.....	27
Figure 26. Tab and Slot Detail.....	28
Figure 27. Revised Hydraulic Tensioner Mechanism.....	28
Figure 28. Manual Adjustment Torque vs. Tension Curve. ....	30
Figure 29. Crowned Roller Details. ....	32



Figure 30. V-Groove Guidance System.....	32
Figure 31. Belt Tension Diagram.....	39
Figure 32. Belt Length Diagram. ....	41
Figure 33. Deformed Belt Diagram. ....	41
Figure 34. Upper Cylinder Mount Weld Analysis.....	46
Figure 35. Upper Adjuster Plate FOS Plot.....	48
Figure 36. Tube Hydraulic Assembly.....	51
Figure 37. Upper Slider Tube. ....	51
Figure 38. UHMW Bushing.....	51
Figure 39. Lower Slider Tube.....	51
Figure 40. Upper Mount. ....	51
Figure 41. Lower Mount. ....	51
Figure 42. Timken Flange Bearing. ....	51
Figure 43. Gusset. ....	51
Figure 44. Lower Cylinder Mount. ....	51
Figure 45. Upper Cylinder Mount. ....	51
Figure 46. Hydraulic Tensioner–R Isometric. ....	51
Figure 47. Hydraulic Tensioner-R Side.....	51
Figure 48. Upper Mount-R. ....	51
Figure 49. Upper Mount-R Flat Pattern.....	51
Figure 50. Upper Slider Tube-R. ....	51
Figure 51. Lower Slider Tube-R.....	51
Figure 52. UHMW Bushing-R.....	51
Figure 53. Lower Mount-R.....	51
Figure 54. Gusset2. ....	51
Figure 55. Gusset1. ....	51
Figure 56. Upper Cylinder Mount-R. ....	51
Figure 57. Lower Cylinder Mount-R.....	51
Figure 58. Upper Adjuster Plate .....	51
Figure 59. Adjuster Bolt .....	51
Figure 60. Hydraulic Schematic. ....	51

## INTRODUCTION

### Background

The purpose of this project was to design a pick-up belt tensioning system for an almond harvester. The current method for harvesting almonds from the orchard floor employs what is known in the industry as a pick-up belt. These belts are made of short, wide sections of rubber belting with cleats that are fastened at regular intervals. The pick-up belt can be seen in Figure 1 at the front of the harvester just behind the front wheel. The belt cleats are typically 4 to 5 inches tall and are responsible for scooping the windrow of nuts off the ground and into the harvester. One problem that is common to this type of pick up belt is premature wear, which can lead to in-harvest breakdowns and costly, time intensive repairs. A common cause of premature belt wear and failure happens when small rocks get between the belt and the roller shafts that support and drive the belt. When this happens, the belt must stretch to pass over the radius of the shaft and the obstruction, namely a rock. This causes a near instantaneous increase in belt tension, which causes high stresses in the belt. When harvesting in a particularly rocky field, this can become a significant problem and can cause the belt to tear at the joint.

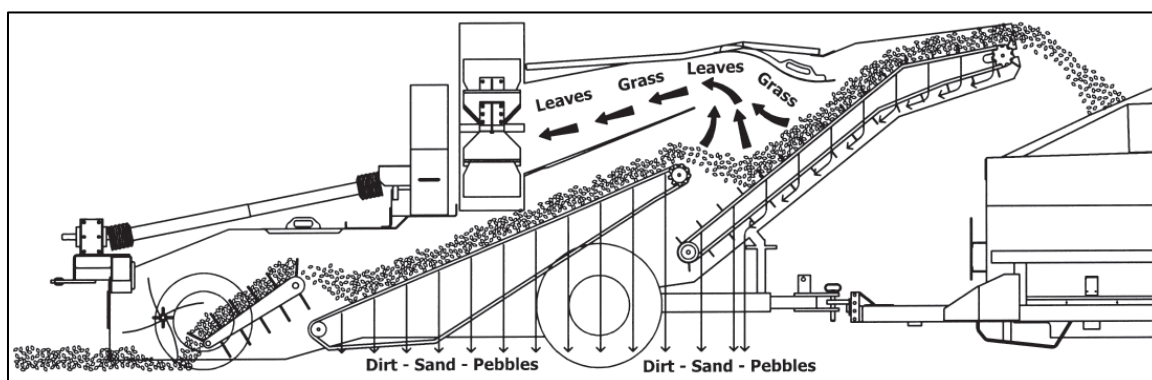

Figure 1. Flory 850 Almond Harvester Schematic (Flory Industries, 2012).

Another mode of premature failure is caused by a buildup of dirt between the lower roller and the pick-up belt. This causes the effective diameter of the lower roller to increase, which increases the tension on the belt. This increase in tension often leads to a decreased belt life as the dirt builds up hour after hour of operation.

### Justification

This project will consist of designing multiple parts of the pick-up belt system, with the goal of reducing premature wear and untimely maintenance during harvest. The ultimate goal is to lengthen belt life and reduce operating costs. The deliverables will be a

prototype belt tensioning mechanism that has been tested on the pick-up belt tester that has been supplied by Flory Industries for this project. The intention of the project will be to provide beneficial development of a tensioning mechanism that could be potentially implemented on a harvester for more extensive testing. By reducing the tension spike cycles that a pick-up belt undergoes during normal operation, the belt life should increase and reduce the replacement to only scheduled intervals. Also, the tensioner has the potential to improve upon the current method of initial belt tensioning, which relies upon experience with the product and several attempts to achieve the ideal tension. Additionally, if a belt is under-tensioned initially the belt's friction drive can quickly damage the belt. A tensioner would help address this problem as well.



Figure 2. Pick-up Belt Mounted in Tester.

The current pick-up belt design utilizes threaded rod to adjust the location and tension of the pick-up belt. This system is effective, but has the potential for operators and mechanics to improperly tension the belt. Pillow block style bearings are used to mount the pick-up belt shafts, and these bearings are mounted on moveable mounts. The threaded rod is adjusted through a mounted plate to push on the upper bearings to apply tension to the belt. Also, the lower bearing is adjusted with a smaller threaded rod. This is for the purpose of aligning the lower shaft square to the harvester body. This lower adjustment is fixed before the belt is tensioned, and all the tensioning force is applied with the upper adjustment threaded rod. The manual tension system is shown in a SolidWorks model below (Figure 3).

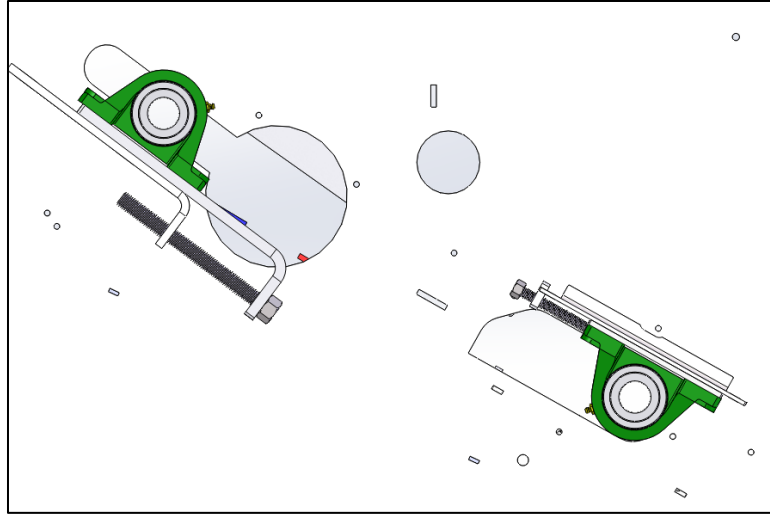

Figure 3. Manual Belt Tension System.

To test the prototype tensioner, a pick-up belt test unit will be used. This test unit was designed for testing pick-up belts that are constructed at Flory Industries and installed on production harvesters. The tester allows for a quality control step in the belt fabrication process which minimizes problems in finished machines due to faulty belt material. This tester is designed and built very similar to the actual harvester pick-up system to simulate the conditions when a belt is operated. For this project the tester is a vital component because it will allow for testing that is similar to some of the conditions a pick-up belt undergoes in the field. The ability to test a tensioner mechanism in a situation that is similar to an actual harvester creates a lower investment research situation than if a production harvester would have to be fitted with an initial prototype. This should help shorten the prototype time should the design solution be pursued further in the future.



Figure 4. Pick-up Belt Tester.

## LITERATURE REVIEW

At the onset, research was conducted to identify the feasible scope of this project. This research was beneficial, and the information found was used to guide aspects of the design of the tensioner system.

The first item of interest was information concerning constant force devices. The tensioner system would only be acceptable with the ability to provide constant force to the belt. The system is needed to protect the belt from tension spikes, and to achieve this outcome completely a constant force device is necessary. There are several types of constant force devices found in industry: constant force mechanical springs, constant force gas springs, and a hydraulic system with a constant pressure are a few examples.

The final part of this literature review and research concerns the pick-up belt itself. Information was gathered from Flory Industries service department to give a broader picture of the actual performance of pick-up belts in the field. This information was gathered from Flory's own service department, as well as from their network of dealerships and repair facilities.

### Mechanical Springs

The first and simplest type of tension device to be examined is a mechanical spring. However, most mechanical springs are linear, meaning that as the spring is deflected, the spring force increases linearly with deflection. A graph of force versus displacement is shown in Figure 5 to illustrate the relationship between force and displacement.

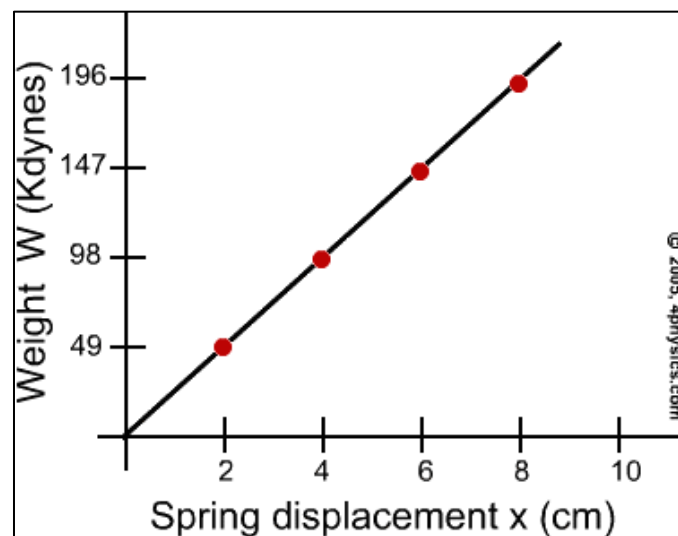

Figure 5. Linear Spring Example (4physics, 2012).

For this application a linear spring would allow for deflection of the system to compensate for obstructions, but the belt tension would rise proportionally to the size of the object passing between the belt and the shaft. This would alleviate some of the problem, but would be an incomplete solution. There are springs used in industry that are referred to as constant force springs, however upon investigation it appears that this type of spring is used in low force applications, such as in rotating systems like clocks and timers. Constant force springs are often wound radially, so that they can exert a constant force tangentially to the outer surface spring. An example of a constant force spring is shown below in Figure 6. This type of spring works well for certain applications, but for a high force belt tensioning device being designed in this project there are better options available.



Figure 6. Coiled Constant Tension Spring (Vulcan Springs, 2012).

While not ideal, the most practical solution to the belt tension spike problem would be to use a mechanical compression spring loaded device. This would be significantly cheaper than most other solutions, but would allow for an increase in belt tension when encountering an obstruction. This would certainly be an improvement over the current situation, where both rollers are fixed solid and the belt tension increase is dramatic. This project will seek a secondary design that uses linear springs as a low cost alternative to other types of systems.

### **Gas Springs**

The second type of constant force device is a gas spring. Gas springs are often nitrogen filled, and operate on a principle of constant force due to piston area differences. The pressure on both sides of the piston is the same, and the only difference from side to side is the area on which the gas pressure can act. The difference between the rod side area and the non-rod side area is the net area. The gas pressure multiplied by the net area is the force that the spring will generate. The gas is allowed to move freely to both sides of the piston so that during the stroke the gas does not compress and raise the pressure on the compression side. As a gas spring compresses however, a slight increase in force will occur due to the overall reduction in volume as more of the rod occupies gas volume.



Generally this effect is small compared to the nominal force exerted. A typical gas spring is shown below in Figure 7 identifying the key components.

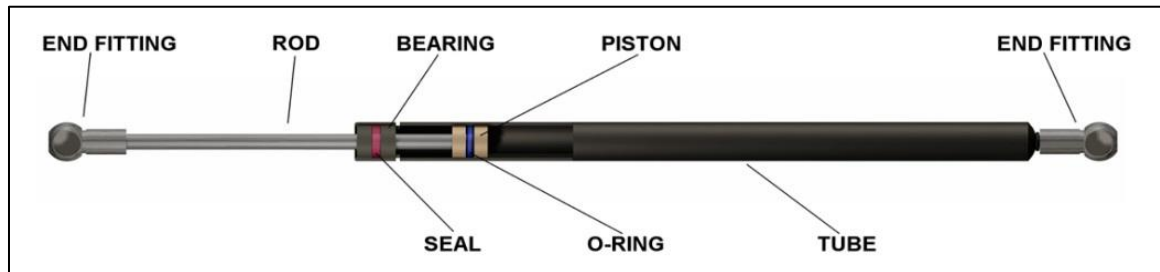

Figure 7. Cutaway Diagram of a Typical Gas Spring (Titan, 2012).

Many gas springs can be adjusted, allowing the force to be changed by adjusting the gas pressure. The simple design and operation of a gas spring makes it an excellent choice for use in applications where a constant force is needed and adjustment is minimal. Many companies offer adjustable cylinders so that the optimum pressure can be located and communicated to the supplier. Then, for production, non-adjustable cylinders are used to reduce cost. Often, the pressure of the chamber can be reduced, but adding pressure is difficult due to the high pressure and the nitrogen gas charge. Additionally, as the spring leaks and wears there is the potential for a force drop off, and in many cases the time and subsequent cost to recharge a gas spring would be detrimental to operation of a harvester, where consistent performance over the life of a component is a demanded by the customers. The spring supply company LesjoFors (2012) lists many of the recommendations they give their customers so that maximum spring life can be obtained. They recommend that the spring be mounted free from vibration and that it be mounted such that the radial loading is minimized. For the pick-up belt tensioner application it is nearly impossible to eliminate vibration, and it is a logical assumption that factors such as these will limit the life of a constant pressure, constant force gas spring. So, in conclusion, the constant force gas spring appears to be a viable option to design around in the tension system, but significant precautions would have to be taken to keep the rod clean as well isolating the spring from vibration.

### **Hydraulic System**

Another type of system that could be used as a constant force device is a hydraulic cylinder supplied with a constant hydraulic pressure. This would allow for a constant force if the pressure remains constant during the deflection while an obstruction passes between the belt and the shaft. The hydraulic system on a harvester would allow for the use of a hydraulic system as long as the tension system did not require much flow. When an obstruction passed through the system a small flow would be required to relief back to

the tank and then the pressurized system would restore that volume of oil to the cylinder to allow for constant force in the tensioner system.

The Eaton Hydraulics Manual outlines the operation of two types of pressure reducing valves that can be used to limit the downstream pressure in a circuit. The two primary types are the direct acting reducing valve and the pilot operated reducing valve. The operation and the benefits are similar, but the pilot operated allows for more precise pressure settings and operation. These valves operate by similar principles, and both valves incorporate a drain to the tank that returns oil that operates the control valve. One issue that must be dealt with when using either valve is the reverse flow that occurs when the pressure attempts to spike when encountering an obstruction in the system. A direct acting pressure relief valve could be teed into the circuit for the pressure relief during obstruction. The detailed solution to this problem will be addressed in the design section of this report and the hydraulic schematic.

#### Direct Acting Reducing Valve.

The direct acting pressure reducing valve is simple and effective in operation and shown below in Figure 8. The direct acting valve operates off direct spring force, and when the pressure is above the set point the spring holds the valve open, allowing flow into the system behind the valve. When the pressure downstream overcomes the spring force the valve closes and the flow stops. In this manner the downstream pressure is limited to the set value (Eaton, 2008). This valve does not allow for reverse flow while maintaining the reduced pressure.

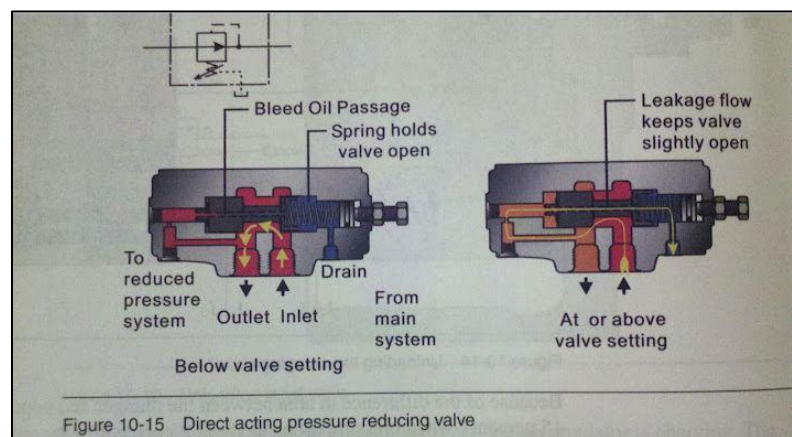

Figure 8. Direct Acting Pressure Reducing Valve (Eaton, 2008).



### Pilot Operated Reducing Valve.

The pilot operated reducing valve operates using the same principles as the direct acting valve, but with greater control over the pressure setting. This is shown below in Figure 9. The pilot operated valve has an adjustable pilot spring that allows for precise control of the pressure setting, as well as enabling the valve to respond the same for various pressure settings (Eaton, 2008). This valve allows for reverse flow, but only when the downstream pressure is the same or greater than the system pressure. To use either valve and allow for the reverse flow when the cylinder compresses an additional check valve will be needed in the circuit.

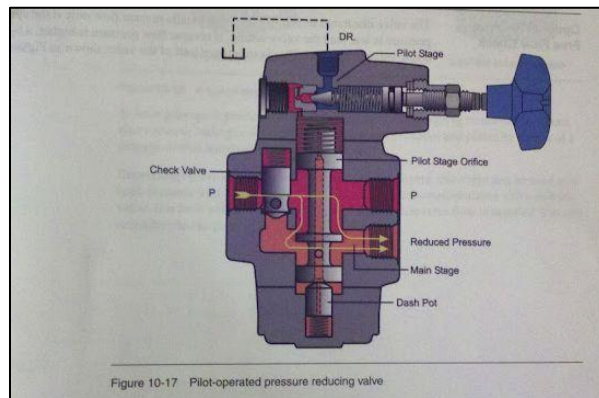

Figure 9. Pilot Operated Reducing Valve (Eaton, 2008).

### **Pick-Up Belt Details**

The current pick-up belt used in the almond harvesting industry consists of a flat rubber belt with attached cleats. This belting material is stiff, and has angle iron riveted to it at regular intervals. The pick-up tines and rubber flaps are bolted to the angle iron. After the appropriate pieces are bolted together, the belt is formed into a continuous loop and joined using a standard belt joint. The belt is shown in a SolidWorks view in Figure 10 (only showing the attached cleats on the top of the belt). The rubber carcass is shown in a grey color; the rubber fingers are shown as blue; the gold pieces are the angle iron pieces that attach to the belt; the green pieces are the wire stiffeners that support the rubber fingers; and the joint is shown in red. The joint shown is where failure typically occurs when an obstruction passes through the pick-up belt system, and if the failure does not occur from one incident, the belt life is still reduced and this can lead to elevated operating costs and expensive, unexpected repairs during harvest.

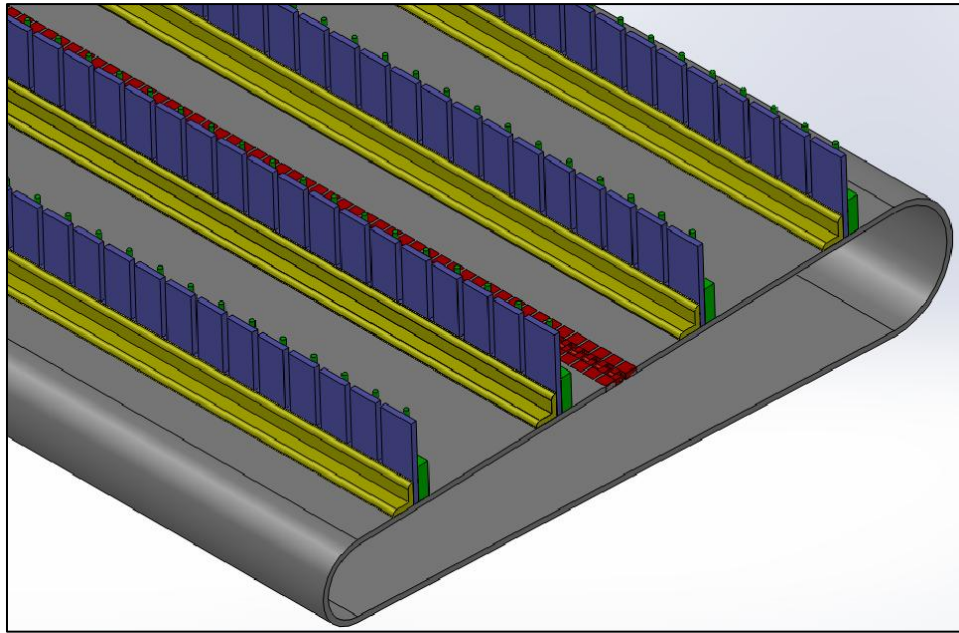

Figure 10. Pick-Up Belt Model in SolidWorks.

Some detailed information regarding pick-up belts was kindly provided by Jason Flory, (Flory Industries, Service Department Manager). During the life of a pick-up belt, it will encounter a significant amount of dirt that builds up between the belt and the lower roller (shaft). When properly tensioned initially, this buildup of dirt increases the effective diameter of the lower roller, which increases the tension of the belt. When the belt tension increases beyond a normal operating tension, it puts excessive stress on the joint of the belt, and can lead to premature failure. Flory recommends that its equipment operators clean the dirt from behind the lower roller daily to avoid over tensioning of the belt. However, in practice this kind of maintenance is postponed or overlooked because a

lack of understanding by the operators of the importance of the maintenance. As an engineer, the purpose of this project is to look at solutions to this problem that can help remove some of the daily maintenance from the operating equation. When properly tensioned, the belts are expected to last on average from 400-600 hours of operation. However, Jason estimates that nearly 30% of the pick-up belts in the field will fail before this life due to improper tensioning. (This includes dirt buildup, obstructions that pass between the belt and the roller, and improper initial tension.) Furthermore, it is estimated that 90% of all premature belt failures can be attributed to over-tensioning. All of this information further emphasizes the potential that exists for innovation and improvements in the pick-up belt mounting and tensioning.



Figure 11. Belt Joint Detail.

Another piece of information that underscores the statistics of belt failures is the cost associated with pick-up belt replacement. A complete pick-up belt replacement typically involves a replacement of the lower 3" roller shaft, the 2 lower roller bearings, and the pick-up belt. This service takes about 3.5 hours of shop time and costs approx. \$3000. However, in the case of a really early premature failure only the belt would need to be replaced.

All of this information proves that a tensioning mechanism could provide significant operating cost reductions if it could consistently lengthen the service life of the belt to the expected 600 hour limit. Also, if the tensioner design could make it easier to correctly tension the belt it could save time in assembly, in service situations, and in the field during harvest.

## PROCEDURES AND METHODS

The scope of this project is intended to be narrow, with several definitive conclusions as the result. It is intended that this project evaluate the effect of the designed and built solution to the belt tension problem. This project included a design phase, a construction phase, and a testing phase. Also, a revised design section is included in the design improvement section of the results. These revisions address design issues that became apparent during fabrication and testing.

### Design Procedure

The principle design element is the tensioner device, and the design of the tensioner device is described in this section. There were several design factors that were considered before the project began. The first factor to evaluate was the method of tension application. There are two methods that will be considered in this project, a hydraulic tensioner method and a simpler spring loaded device. There are several pros and cons to each type of system, and each of them will be addressed in greater detail later in the report. This report will examine each of these systems separately, and propose a design solution using each method.

### Design Constraints.

Many of the initial design constraints are based on the physical dimension of the standard pick-up belt and the corresponding harvester. This includes a belt width of 48 inches, and a shaft to shaft (center to center) distance of approx. 26 inches. This center to center distance can vary from belt to belt, so the distance needs to be considered in the tensioner design. The upper roller shaft (Figure 12) is the drive shaft for the belt and is rubber coated for more friction. It has a diameter of 5 inches, which shaft ends of 1.5 in diameter. The lower shaft (Figure 13) is solid steel 3 in diameter shaft with shaft ends of 1.5 in diameter as well. These shafts should be supported by 1.5 in flange bearings, and the mechanism will have to take into account the size of these flange bearings.

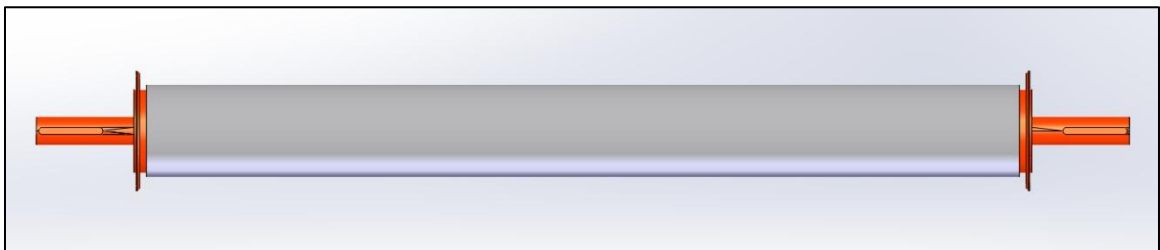

Figure 12. Upper Roller Shaft.

The tensioner mechanism was required to interface with belt tester and so to not affect the ability of the tester to be returned to its original configuration. This means that it

could not be modified extensively. This presented several challenges, including mounting the tensioner around the existing upper bearing mounts and the stiffener angle iron on the side plate of the tester. The tensioner mechanism needed to provide between 800 and 1500 pounds of force.

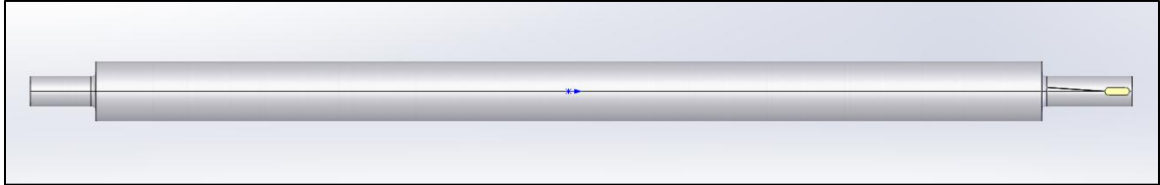

Figure 13. Lower Roller Shaft.

Also, the mechanism needed to accept either a 4 inch stroke or 8 inch stroke hydraulic cylinder that was supplied from Flory's. These are commonly used on other equipment, so using common components was a benefit for sourcing parts. Also, to facilitate a spring mechanism there must be sufficient space for the uncompressed spring length. The previous conditions, among other simple construction factors, drove the design process.

#### Initial Design.

The initial design phase consisted of examining the belt tester for ways that a tensioner mechanism could be attached without extensive modification. The objective was to build both a hydraulic tensioner and a spring loaded tensioner, with one mechanism mounted on each side of the tester to observe the advantages and disadvantages of each clearly. The design progressed with this premise, and both a spring and hydraulic method were designed using SolidWorks 3D parametric modeling software. This type of software is essential for research and development situations where variables are constantly changing and modifications are a necessity. Also, SolidWorks has a built-in Finite Element Analysis package that was used for design evaluations during the design process. The primary design for the tensioner mechanism (Figure 14) centers on the hydraulic cylinder and its ability to provide constant force to the belt at all times. The carriage system consisted of sliding mechanism that will allow the motion necessary for adjustment and relief when encountering an obstruction. The slider was designed from schedule 40 steel tubing with ultra-high molecular weight (UHMW) bushings to facilitate a smooth sliding motion. The smaller pipe selected was 1 in nominally and the thickness between the upper and lower tubes was the region for the bushing. The 2 in pipe was designed to be mounted to a formed piece of ¼ in hot rolled (HR) plate that also mounted the upper bearing. The lower bearing mount attached to the smaller tubes and is the lower sliding mechanism. The hydraulic cylinder was placed parallel to the slider mechanism and was integral to the carriage mechanism. The tube slider is designed to handle any bending introduced to the carriage, but theoretically the loading is directly between the two bearings and is axial along the slider and the cylinder. To minimize any bending on the

cylinder the cylinder was placed as near as possible to collinear with the center to center line of the two bearings.

The second design was a spring loaded tensioner device that consisted of two heavy duty springs per tensioner. This design was focused to be the economical solution to the tension problem. Because of the mechanical spring it is understood that it would cause an increase in belt tension when an obstruction is encountered, but the increase would be linear with the displacement and the magnitude would be determined by the spring specifications. This type of tensioner consisted of a few fabricated components as well as the purchase of two springs and is significantly less expensive than the hydraulic system, which has several expensive components such as the cylinder and the hydraulic valves.

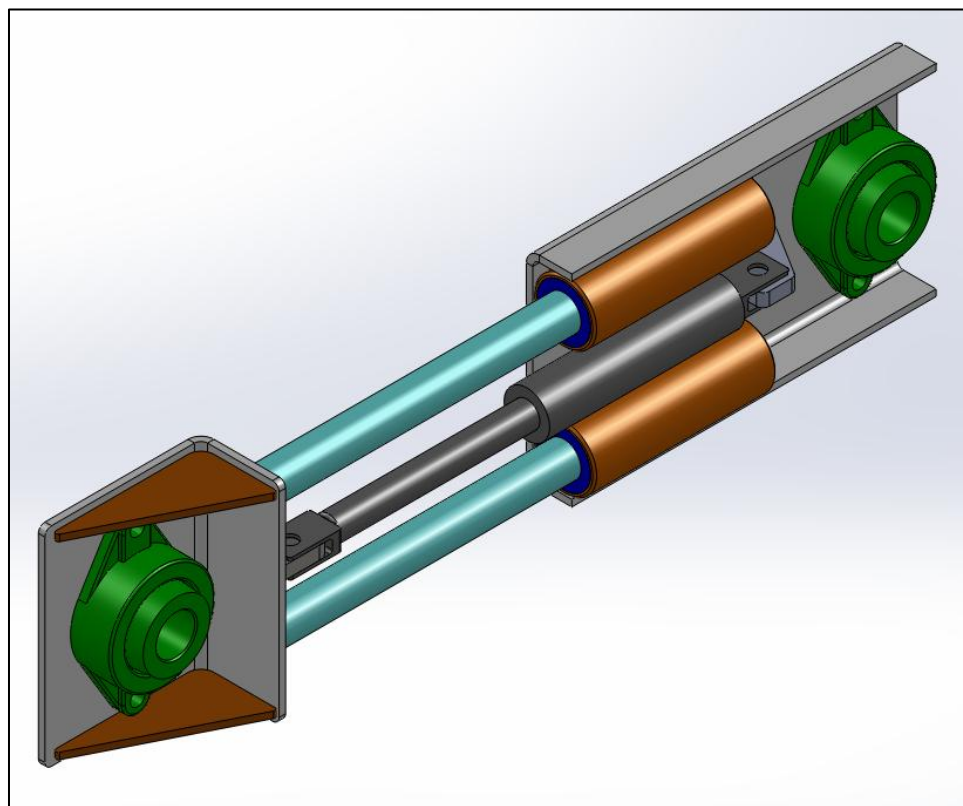

Figure 14. Hydraulic Tensioner Design.

The spring loaded tensioner was designed to be constructed from several of the same parts as the hydraulic mechanism, but have several unique features to handle the adjustment issues associated with the springs. The spring tensioner design is shown in Figure 15. The two upper slider tubes will be joined by pieces of 3/8 HR plate that fit the round cross section of the tubing. These mounts will be what guides the adjustment piece, the 3/4 diameter threaded rod. This rod will be what applies the compression force to the springs so that the belt can be properly tensioned. This will require the fabrication of a sliding plate that will apply the force to the springs.



As the hydraulic cylinder is the focus of the hydraulics tensioner, so are the springs in the spring tensioner. The springs must satisfy multiple requirements and constraints if they are to be a viable option. As noted in the initial design constraints, the tensioner should be capable of applying up to 1500 lbs of force to the belt on each side. This requires that each spring be able to apply up to 750 lbs. Also, to optimize the system the springs should have a low of stiffness factor so that the linear increase of force is minimized. Obviously, this means that a longer spring would be necessary to achieve the requisite preload. Another spring constraint is that they need to have an inside diameter such that they fit over the lower slider tubes.

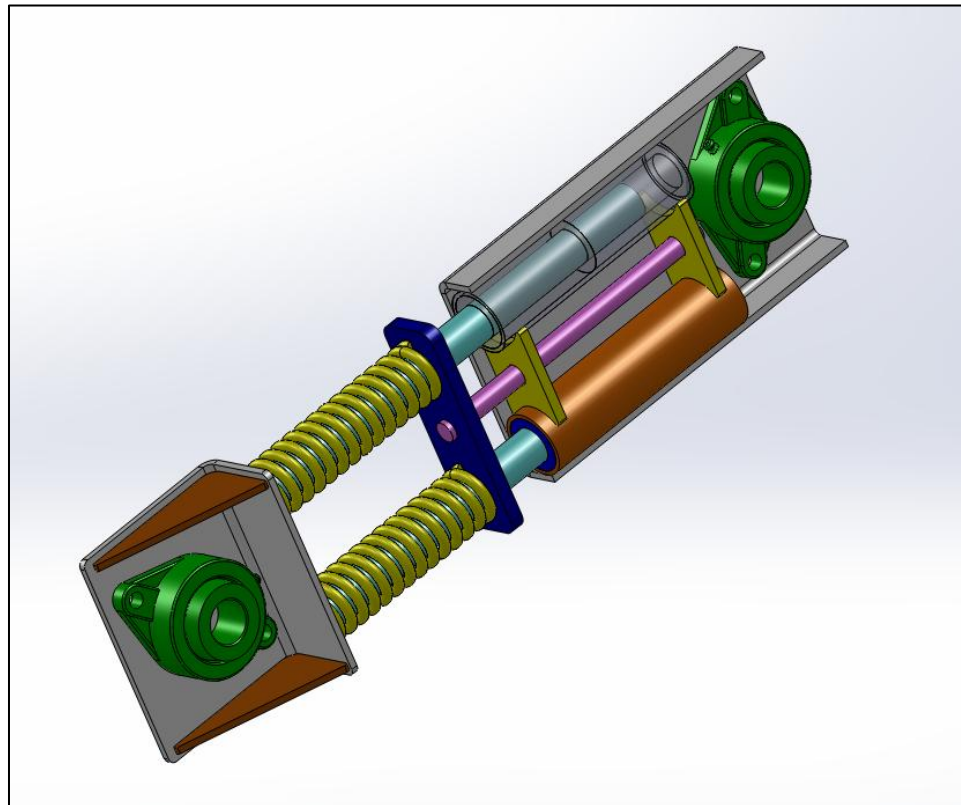

Figure 15. Spring Tensioner Mechanism.

After searching through several spring manufactures data sets, a spring sourced through McMaster Carr was chosen. This spring has an initial length of 8 inches, with a 2.187 in OD. The wire diameter of the spring is 0.375 inches and the compressed length of the spring is 5.57 inches. This specific spring has a k factor of 371.8 lbs per inch of deflection and a maximum force of 907 lbs. Use of this spring would allow for a range of tension force up to 1800 lbs. However, to allow for travel of 1 inch 371.8 lbs of preload would not be available. This means that to still allow 1 inch of travel the maximum preload would be 1050 lbs. Because the preload of 1500 lbs is rather high and unusual, this spring was still chosen for the spring loaded design. Thus, when encountering

obstacles or dirt build-up, the maximum force that could be applied by the spring to the belt is 1800 lbs. However, according to calculations regarding the spring's ability to be solid safe, the spring should not be completely compressed. This calculation is shown in *Appendix B Spring Solid Safe Calculation*. So, the springs are not a good option if the full 1500 lbs of pre-tension force are needed because after encountering an obstruction the spring may not return completely due to shear stress failure in the spring. In a lower tension situation the springs would be fine.

After considering the pros and cons of each design, it was decided to only fabricate the hydraulic tensioner. Also, because of the nature of the drive system of the tester, a tensioner for the drive side of the tester would have interfered with several components. This would have required extensive modification to the drive side of the tester and, due to time constraints, the tensioner for this side was bypassed for this project.

#### Design Calculations.

The first calculation for the tensioner project was to determine the relationship between the force supplied by a tensioning device and the resulting belt tension. Also, the amount of correct belt tension needed to be estimated for further design calculations. The relationship between the forces is shown in *Appendix B* under the *Design Belt Tension Specification* subheading. The estimate for belt tension was supplied by Flory Industries, and the range specified was 800 lbs to 1500 lbs of tension. For any additional analysis the maximum value of 1500 lbs was used.

The next calculation is for the sizing of the hydraulic cylinder. This calculation, which can be seen in greater detail in *Appendix B* under the *Cylinder Sizing* subheading, yielded a requirement of a 1 inch diameter cylinder. However, a 1.5 inch cylinder was donated to the project by Flory Industries, and, since it would supply more than enough force, it was used for the hydraulic tensioner. The cylinder used was a 4 inch stroke by 1.5 inch diameter welded hydraulic cylinder with ¼ inch female pipe thread ports.

The third design calculation is for the amount of belt length increase during deflection due to a rock or similar obstruction and the resulting increase in belt tension for a mechanically tensioned system. This calculation assumes a 1 inch diameter round obstruction. The resulting belt stretch is 1.37 inches when encountering a 1 inch obstacle. When operated using a fixed mount this amount of deflection causes a 387 pound increase in belt tension. This calculation is shown in *Appendix B* under *Belt Stretch Calculation*.

Another important calculation for the hydraulic system is for the fluid flow that is displaced when an obstruction is encountered. This calculation is shown in *Appendix B Fluid Flow during Deflection* and yields a flow of 1.77 cubic inches during deflection. This flow, while small, is worth considering because for the tensioner to operate



effectively this flow must be passed through a relief valve very quickly in order to avoid pressure spikes and thus tension spikes. The follow-up of this calculation is the *Fluid Velocity during Deflection* calculation. This is also shown in *Appendix B*. From this calculation the fluid velocity is shown to be 25 feet per second (FPS) which is near the upper limit of allowable velocities in a hydraulic hose. When excessive velocities are used, excess friction loss is created. However, in this case, the problem is not friction loss but pressure increase to overcome this friction. For a tensioner application the ideal would be that the displaced oil would flow with no resistance, but this is ideal and unrealistic. Because problems can arise with high fluid velocities and slow relief valve opening times, more research should be undertaken to determine if larger hoses and ports are needed for an optimum tensioner. These results should be determined in conjunction with in-field testing.

The next part of interest is the Upper Cylinder Mount and the resulting stress during a maximum load of 1500 pounds. This part was evaluated using the Finite Elemental Analysis (FEA) portion of the SolidWorks software package. This analysis yielded a Factor of Safety (FOS) plot based on the minimum of several different yielding criteria to show the worst case scenario. This resulting FOS plot is shown below in Figure 16. The results are excellent and show that the smallest FOS in the part is approximately 4 times the allowable stress. The welds that secure the mount have been analyzed separately.

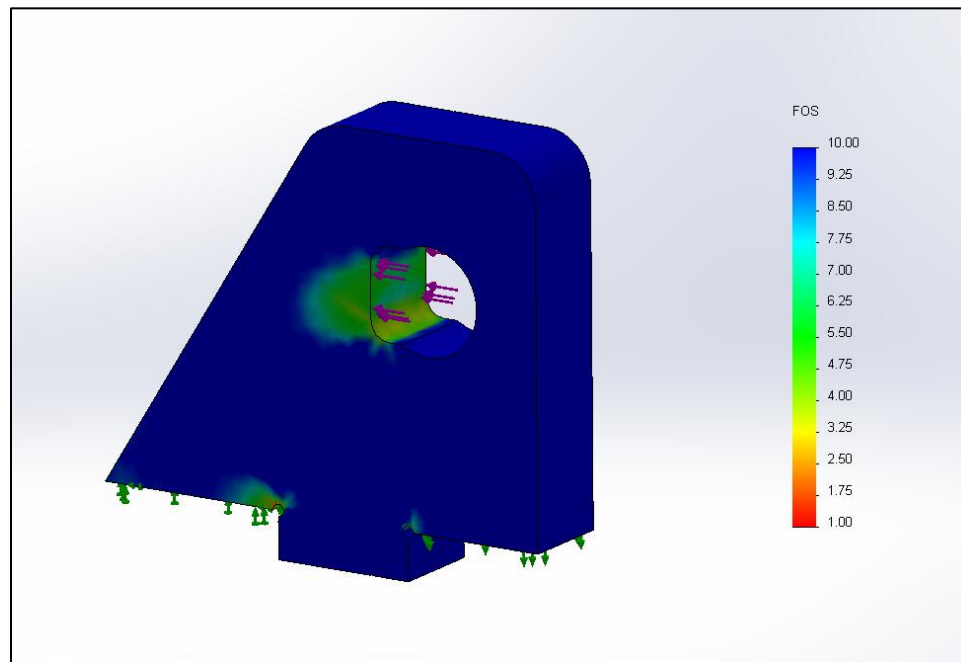

Figure 16. Factor of Safety Plot for Upper Cylinder Mount.

The bolts used to attach the cylinder are analyzed in *Appendix B Cylinder Mount Bolt Shear* and are found to be sufficiently strong.

The weld for the upper cylinder mount was the only critical weld of the assembly because the welds encounter both primary shear stress as well as secondary shear stress due to bending. The welds were analyzed such that the tab and slot does not handle any of the shear stress. This is the worst case scenario and the best evaluation for the design. The weld analysis is in *Appendix B Upper Cylinder Mount Weld Analysis* and yields a result of a Factor of Safety (FOS) of 4.86.

Another FEA analysis was done on the lower bearing mount to evaluate the region where the lower slider tubes and the lower cylinder mount attaches. To evaluate this assembly a simplified part was created to evaluate. The results of this evaluation are shown below in Figure 17. The plot shows that there are some critical regions in the design where the FOS is near 1. These regions are where the sharp corners of the lower cylinder mount interface with the flat surface of the lower bearing mount. This problem could be addressed by enlarging the lower cylinder mount to increase the contact surface area. Also, when welded the actual contact region will be slightly beveled because of the additional weld material. This bevel reduces the stress concentration at the sharp corners.

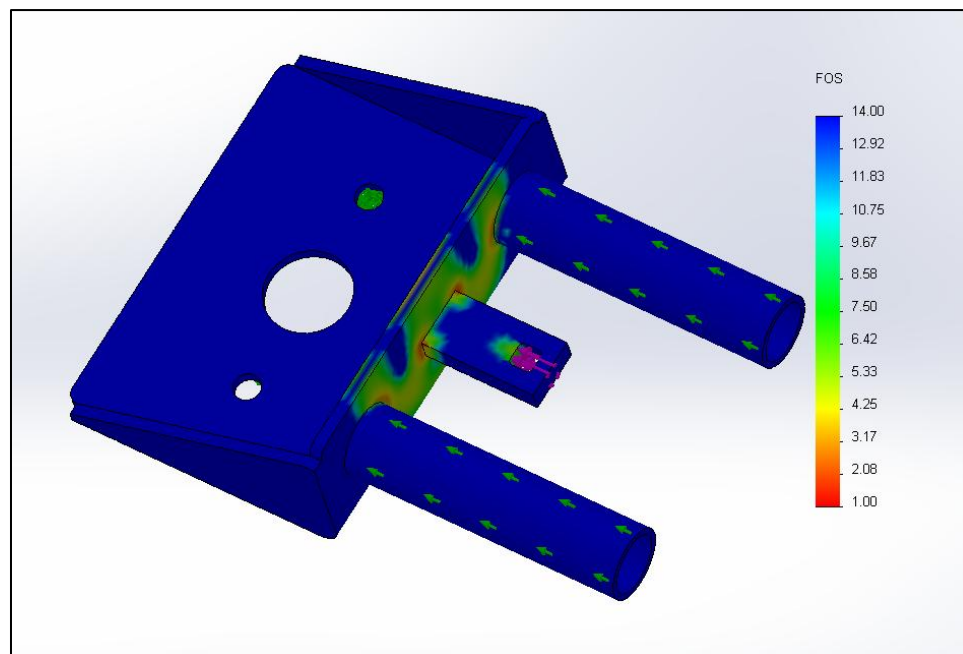

Figure 17. FOS Plot for Lower Bearing Mount and Cylinder Mount.

The FEA software allows for stress analysis of parts that would normally require many separate hand calculations and it superior in accuracy because it takes into account many of the nuances of the model. Hand calculations of this magnitude are not practical and require much generalization. After the design was completed, the process moved into the fabrication stage.

## **Fabrication**

### Fab Parts from Flory Industries.

Due to the nature of the sponsor company, Flory Industries, there was a unique opportunity to have some of the parts fabricated through the fab department at Flory's. These components were then assembled or finished in the BRAE lab 7. The first component that was fabricated by the fab department was the upper bearing mount (Figure 18). This is an important piece of the structure and the more precisely built this part could be, the simpler the final construction would be. Two of these mounts were fabricated and delivered to the project. Due to some indecision at the time of fabrication, the bearing mount bolt holes were left out of the parts and were drilled later using the end mill. The upper mount was fabricated from 0.25 inch hot rolled plate steel.



Figure 18. Upper Mount.

The second part received from Flory fab was the lower bearing mount (Figure 19). This piece also was fabricated without the bolt holes and they were added later using the same milling process. The lower mount was fabricated from 0.25 inch hot rolled plate steel, the same as the upper mount.

The parts that Flory fabricated were processed through the engineering department and then sent via .dxf file to the fab department. The steel was cut using the departments Trumpf laser cutter and the bent using the hydraulic press brake with CNC control. These pieces processed through the fab department showcased the precision that the machines and their operators commit to every day. The final fabricated dimensions were very accurate, with a less than 1/16" error.



Figure 19. Lower Mount.

#### Fabrication of Remaining Parts.

The remaining parts for the tensioner assembly were fabricated in Lab 7 using a variety of equipment and processes. Some of the equipment used included the Pratt and Whitney lathe, the Victor end mills, a Lincoln welder and various small tools. Many of the techniques for fabrication were taught during the BRAE 129, BRAE 421, and BRAE 422 classes and once again the practical experience proved valuable when constructing this project. The part drawings of the assembly and individual components are located in *Appendix C* under its corresponding figure number.

The first parts to be fabricated were the upper slider tubes (Figure 37). The purpose of the upper slider tube is to mount to the upper bearing mount and support the UHMW bushings and the lower slider tubes. These tubes were constructed from 2 inch (nominal) schedule 40 steel pipe. The upper tubes were cut to the proper length using an upright band saw. The tubes were then chucked in the lathe and a small chamfer was cut to both the inside and the outside of each end. The inside chamfer was to allow the UHMW bushing to be pressed in more easily and the outside chamfer's purpose is purely for looks and for a safer edge. Two of these tubes were used for each tensioner assembly.

After the upper tubes were fabricated, the UHMW bushings (Figure 38) were machined on the lathe. These bushings were fabricated from 2.25 inch diameter UHMW round stock. The bushings were initially machined to the appropriate outer diameter using the lathe and a 4-jaw chuck (Figure 20). The UHMW machines easily, so a high speed and a relatively fast feed rate could be used. The main problem when machining plastics is the large amount of deflection that occurs when turning the material. To help combat this, the tailstock with a rotating center was used. This ensured that at each end the deflection would be negligible, and in the center the deflection would be limited to an acceptable

amount. After turning the bushings to the correct outer diameter, they were pressed into the upper slider tubes. Finally, the upper slider and bushing assembly was remounted in the lathe, again using the 4-jaw chuck, and the inside of the bushing was bored to the correct diameter using a boring bar. At this point in the construction, the lower slider tubes would fit into the bushings, but with a very tight fit. This tight fit was addressed during the fabrication of the lower slider tubes.



Figure 20. Machining the UHMW Bushings with the Lathe.

The lower slider tubes (Figure 39) were the final component of the slider mechanism to be completed. The lower tubes were constructed from 1.25 inch (nominal) schedule 40 steel pipe. As noted above, initially the slider tubes fit tightly in the UHMW bushings. This was resolved by polishing the lower slider tubes with different grades of emery cloth until a smooth fit was achieved. These tubes were also lightly greased when inserted into the bushings. After a good fit was obtained, the lower tubes were cut to the correct length for the tensioner assembly using the band saw. Finally, the tubes were chamfered using the lathe for a better fit and to avoid the tubes scoring the bushings during travel. Because the initial idea was to make the assembly such that it could be spring loaded the total travel of the assembly was over 7 inches. After the decision was made to make the prototype assembly hydraulic the maximum travel needed was 4 inches due to the length of the hydraulic cylinder. This means that the lower tubes would not have needed to be so long and have so much travel, but design changes will be discussed in the revised design section of this report.

After completion of the slider parts, only a few small components remained to be fabricated. Two such components were the upper (Figure 45) and lower (Figure 44) cylinder mounts. These mounts were simple, but yet had to be robust because they essentially transfer all of the tension force from the lower bearing mount to the upper bearing mount. These mounts were constructed from 1/2 inch hot rolled plate steel and cut using the band saw. Each of these mounts had a 0.5625 inch diameter hole drilled for



mounting the cylinder. After the mounting holes were drilled, the mounts were welded to the assembly using a MIG process.

The final component of the assembly was the mounting tab that fixed the tensioner assembly to the side plate of the belt tester. This mount was constructed from 3/8 inch hot rolled plate steel and was also cut using the band saw. Two 3/8 inch diameter mounting holes were drilled in the mounting tab so that it could be fastened to the belt tester. Finally, the tab was welded to the back side of the upper bearing mount. This mount was a simple solution to mount the assembly during prototyping on the belt tester and is not an important part of the actual tensioner assembly. In a production setting, the mounting of such a tensioner would be very different and the mounting tab would not be necessary.

#### Buyout Parts.

The final components to finish out the assembly were not fab parts but were sourced from Flory Industries. These components included the mounting bearings and the hydraulic cylinder.



Figure 21. Timken 1.5" Flange Bearing.

The bearings selected were 1.5 in diameter flange bearings (Figure 19, Figure 42) that would mount to the upper and lower bearing mounts and support the top and bottom roller of the belt tester. These bearings are Timken heavy duty roller bearings. The bearings also include an eccentric lock collar that is used to lock the bearing to the shaft on which it is installed.

The last and most important component of the assembly was the hydraulic cylinder. This also was sourced from Flory's and is a custom cylinder that is built for them according to their specifications. The cylinder has a bore of 1.5 inches and a stroke of 4 inches. This 4 inch cylinder was chosen over an 8 inch stroke cylinder because of the limited space

between the shafts. Also, 4 inches of travel is more than enough for initial tensioning purposes. The cylinder has clevis style mounting brackets with holes for mounting with ½ inch bolts. For the hydraulic connection, the cylinder contains ¼ inch female pipe thread ports. For connection to the hydraulic hoses pipe to male JIC adapters were used.

After the components were either sourced or fabricated, they were assembled to create the tensioner mechanism. The upper slider tubes were attached to the upper bearing mount using a MIG welding process with care taken to not put too much heat into the UHMW bushings that remained in the upper sliders. The cylinder mounts were also attached similarly. The lower slider tubes were attached to the lower bearing mount by welding completely around the tubes as they contacted the lower mount flange. Great care was taken during these processes to keep the assembly square and the sliding mechanism warp free so that it would still travel smoothly. After welding the assembly together the cylinder and bearings were attached using the appropriate ½ inch hardware. Upon completion, the assembly was attached to the belt tester in preparation of testing (Figure 22).

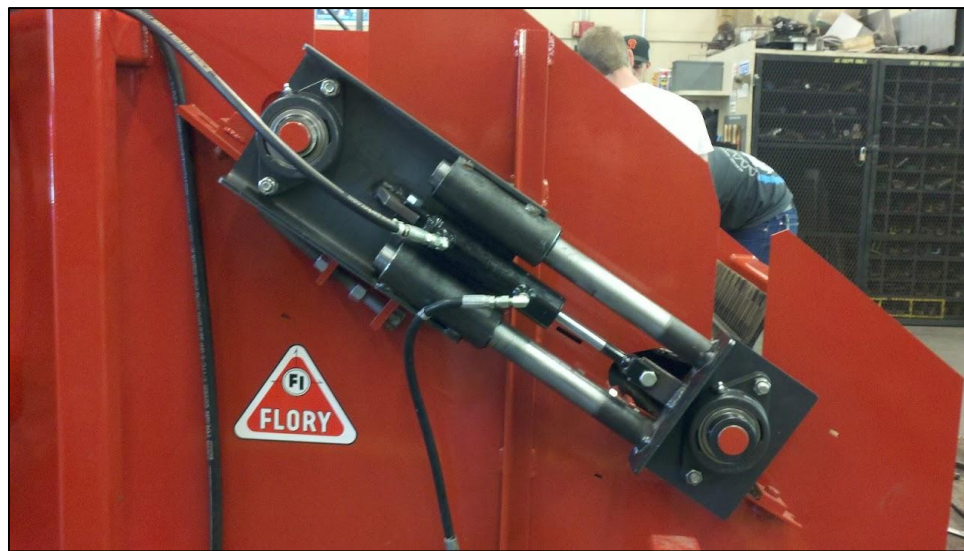

Figure 22. The Completed Prototype Hydraulic Tensioner.

## **Testing**

### **Pressure Testing / Range of Motion.**

After completion of the assembly it was initially tested to ensure that the slider assembly did not bind or fail when cycling through the entire 4 inch stroke of the cylinder. The pressurized testing was accomplished by using the BRAE hydraulic power unit (Figure 23), which consists of a pressure-compensated piston pump and electrically controlled valve manifold set up. This was used to deliver a specific pressure to the cylinder, as well as actuate the cylinder.



Figure 23. BRAE Hydraulic Power Pack.

Upon pressurization and actuation the slider mechanism slid smoothly with no problems and behaved as expected. The sliders were greased to decrease some of the friction between the lower tubes and the UHMW bushings. After checking the range of motion, the testing moved on to the dynamic phase. An important part of the range of motion test was to determine if the mounting bearings would misalign sufficiently to allow the obstruction to pass through and the tensioner to operate correctly. The bearings were seen to have plenty of misalignment so that turned out to not be a problem. However, because it had been decided to pursue the fabrication of one tensioner, the drive side of the belt system remained fixed with respect to the center to center dimension. This caused no problems statically, but under dynamic testing there were some belt centering issues that will be discussed later.

#### Dynamic Testing.

After initial testing was successful, the next step was dynamic testing. This phase of testing was important because a chief issue with the pick-up belt system is the dynamic centering of the belt. In a real life situation the pick-up belt must be closely watched as the harvester is in operation and parts wear and dirt builds up on components. If the belt is not tensioned correctly it will pull to one side and significant wear will occur on the side of the belt until the tension is corrected. So, when dynamic testing began the chief objective was to ensure that with a hydraulic tensioning mechanism installed and operating the belt could be tensioned correctly and remain centered on the drive rollers.

To start dynamic testing the mechanism was pressurized to approximately 300 psi and the manual side was snugged up to what felt like the correct tension. The pressure of the power pack was then increased until the tension felt about the same on each side of the belt when deflecting the belt in the center of each side. After the tensions were



determined to be close, the tester was started at a low speed to observe its initial response. The pressure setting was then adjusted on the pressure-compensator until the belt was tracking in the center of the tester. This pressure was approximately 375-400 psi in the various tests conducted. After observing that the belt would in fact operate correctly, the speed of the tester was then varied from the low speed to the full speed setting which is approximately 250 rpm. The speed was increased in several steps to observe the effects of the different speeds on the system, and there were no significant concerns directly relating to the tensioner mechanism at the high speed setting.

After testing the belt at operating speeds, it was then tested for its designed purpose of relieving belt tension when an obstruction is encountered. The speed of the tester was reduced for the initial dynamic obstruction testing so that components would not be destroyed if something unexpected occurred.

The first dynamic test was just to ensure that the system would operate correctly when a large obstruction was passed between the belt and the lower roller. A rock with a diameter of approximately 1 inch was placed in the unit and the tester was operated at a very slow speed. The system traveled as it was designed and the rock passed between the lower roller and the belt. After observing the system in operation, smaller obstructions were used and the speed was slowly increased.

The second and more important part of dynamic testing was accomplished by passing multiple small to mid-size obstructions between the belt and roller at a higher speed. For this test, the obstructions used were machine nuts for bolts of  $\frac{1}{2}$  inch diameter and  $\frac{5}{8}$  inch diameter. These nuts measured  $\frac{3}{4}$  inch in diameter and  $\frac{15}{16}$  inch in diameter respectively. The system was operated with multiple of each size simultaneously. It was difficult to keep the obstructions in the system because as the nuts passed between the roller and the belt they were kicked towards the edge of the belt and out of the system. This was due in part to the fact that only one side of the belt had a tensioner installed. As the speed was increased the system operated well, and there were no major problems that developed during dynamic testing. The tester was operated to a speed of 200 rpm with multiple of the small ( $\frac{3}{4}$  inch diameter) nuts and the tensioner performed well. The tensioner effectively controlled the tension of the belt as it released oil back through the hydraulic system to relieve pressure. Due to the one sided nature of the tensioner, when the obstructions were placed or moved too near the fixed side they unfortunately simulated a test in which there is no relief for the belt tension. This could be remedied by the addition of another tensioner, but in this project that was not feasible due to hardware constraints.

## RESULTS AND DISCUSSION

### **Testing Results**

The testing part of this project went very well, and the results were favorable. The tensioner mechanism operated as expected with no real mechanical problems. When obstructions were passed through the system the hydraulic tensioner behaved as expected and the pressure compensated pump of the power pack kept the pressure constant in the cylinder. The design has a few minor issues that will be discussed in the revised design section of the results. While the tensioner operated without problem, the test results are not entirely conclusive due to the test stand nature of the test. To determine if the design is suitable for production it needs to be fitted on both sides of a pick-up belt on a harvester that is operated in the dust and rocks of the field. This will help determine if the design will hold up long enough in harvesting conditions to be valuable as a production component. However, the testing of this design on a test stand was a first step in a long process. The results from testing, such as design revisions, will be discussed in the following sections.

### **Revised Design**

The revised design (Figure 24) for the hydraulic tensioner mechanism focused on improving several components of the assembly. These changes were to address design problems found during construction, or design improvements that were noted during testing. Also, some of the changes were simply to make the tensioner design more suitable for a production harvester. The assembly drawings and individual part drawings for the revised design are in *Appendix C* and include a –R designation if they were changed.

The first major change was to lengthen the upper bearing mount (Figure 48) and decrease the overall travel of the tensioner. During testing some movement was observed in the slider mechanism and a solution to make the assembly stiffer was to decrease the travel and shorten the distance that the lower mount is suspended. In the initial design, the length was dictated by the possibility of using a spring mechanism, but for a revised and improved design the travel needs to be only slightly over 4 inches, which is the stroke of the cylinder. This much travel is not needed for tensioning the belt but is for belt installation purposes. By shortening the lower slider tubes, less moment is placed on them and thus the lower mount and sprung components should deflect less.

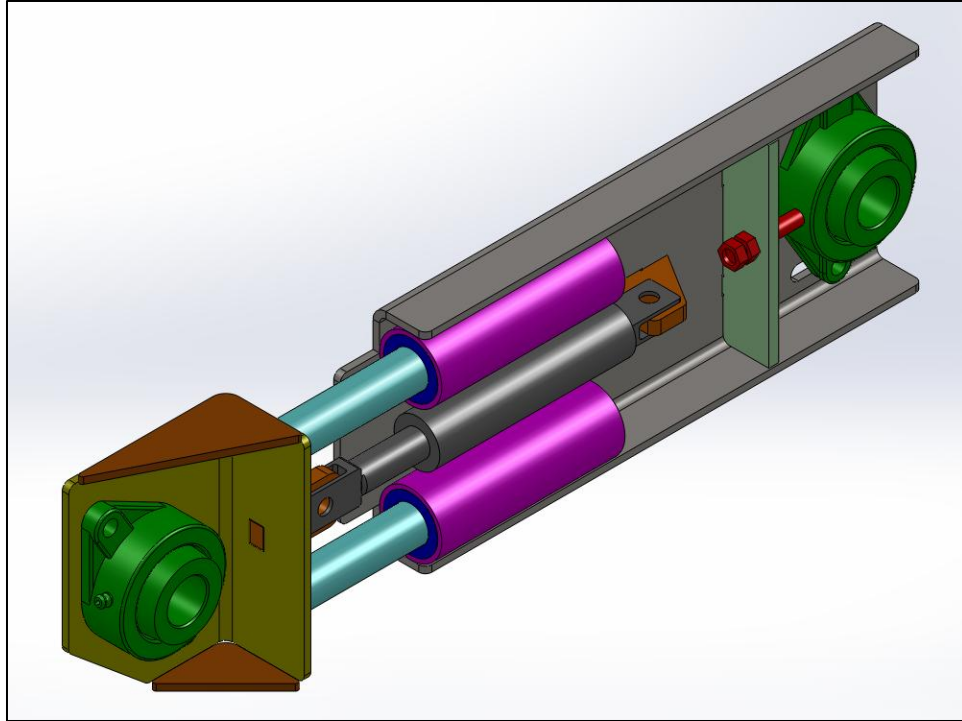

Figure 24. Revised Hydraulic Design.

A significant design addition to the hydraulic tensioner prototype was a manual adjustment mechanism. This mechanism is for the purpose of squaring the upper roller shaft to the harvester (Figure 25). This is to fine tune the upper shaft to ensure the belt will run as straight and square as possible. Because both hydraulic cylinders operate at the same pressure, any adjustment must come from a manual device. The upper adjuster has an adjustment range of just over 1 inch that is accomplished by slots for the upper bearing. Adjustment is achieved by tightening a  $\frac{1}{2}$  inch diameter piece of threaded rod that passes through the adjuster bracket. The threaded rod is red in Figure 25 and the adjuster bracket is light green. The rod pushes on the upper bearing, moving it to the desired location. The adjuster is not intended for tensioning purposes, but for adjusting the location of the upper roller shaft in relation to the side plates of the test stand or harvester.

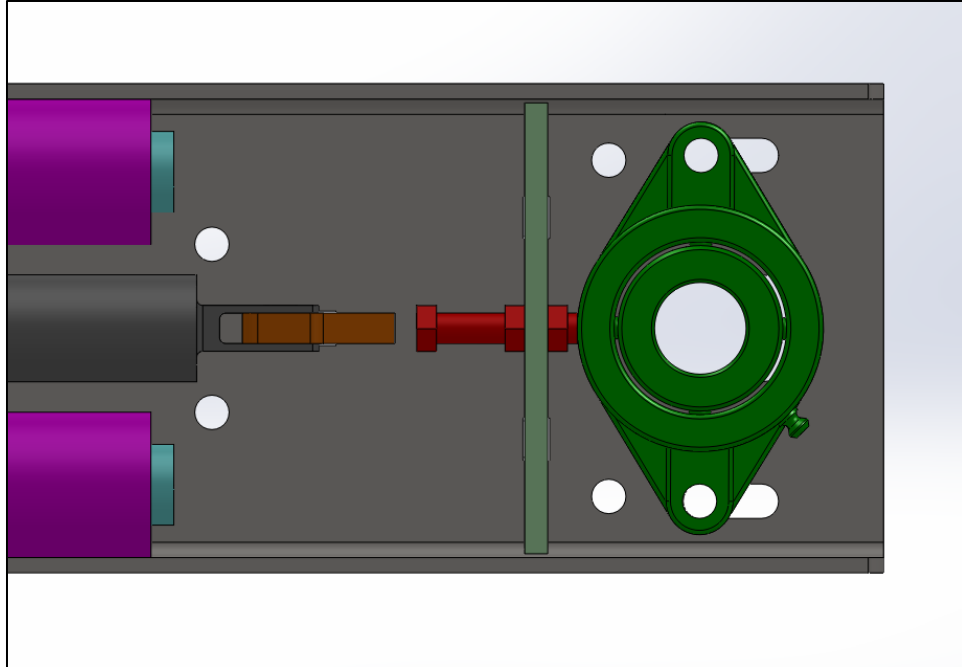

Figure 25. Upper Adjuster Detail.

Another design improvement was to add tab and slot to as many components as possible. This allows for repeatable location of components during fabrication, as well as eliminating the possibility of welding a piece in the wrong location. This also helps eliminate the need to production welders to lay out parts according to dimensions from a drawing, because the tab and slot locates the parts. Tab and slot also can be designed such that it orients parts in the correct direction by the use of asymmetrical tab and slots. For example, on a piece that has two tabs, they each would be different sizes. Tab and slot features were added to the upper and lower cylinder mounts (red), and the upper adjuster plate (light green) and the tab and slot features are shown below in Figure 26.

The lower bearing mount (Figure 53) was also slightly redesigned to allow for more ground clearance. When installed on a harvester, the lower mount and bearing are inches away from the ground. A slight chamfer was added to the lower mount to ensure that it did not contact the ground or create any clearance issues. The also dictated that a second gusset (Figure 54) shape be created. The lower mount can be seen in Figure 26.

A FEA analysis was conducted on the upper adjuster plate (Figure 35) to analyze the effects if the adjuster bolt were to handle all of the belt tension. This is to simulate a situation where the adjuster bolt is used for adjustment while the system is operational and the bolt handles the full load. Also, this simulates a situation where the upper bearing bolts are mistakenly not tightened correctly and the bolt is the only means of keeping the bearing in place. The results show a minimum Factor of Safety (FOS) being

approximately 4. This FOS plot is located in *Appendix B Upper Adjuster Plate FEA Analysis*.

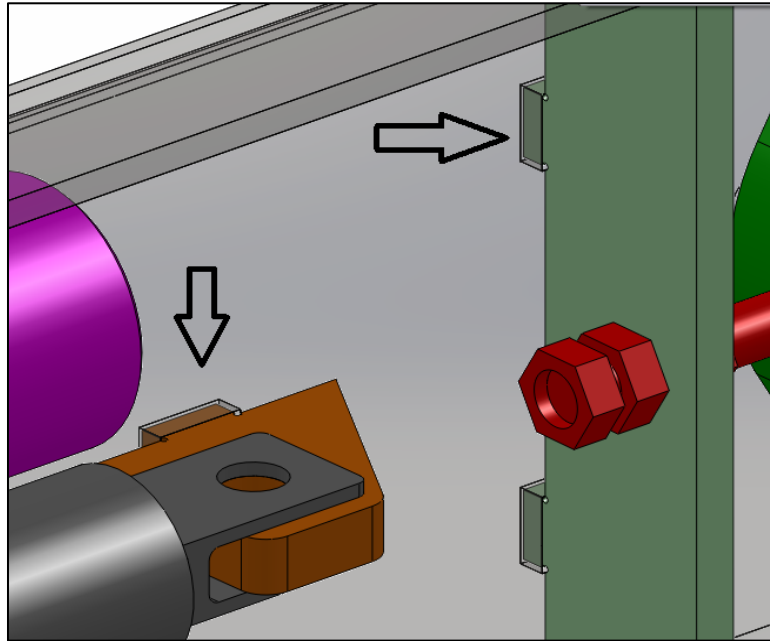

Figure 26. Tab and Slot Detail.

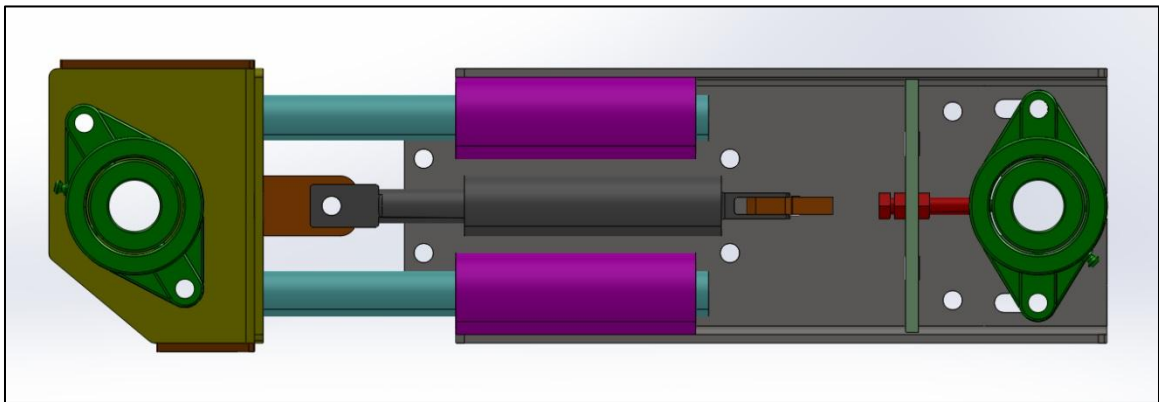

Figure 27. Revised Hydraulic Tensioner Mechanism.

### **Belt Tester Recommendations**

During the course of testing several issues concerning the belt tester were revealed. Overall, the tester functioned as intended with minimal modifications. However, an issue that was apparent from the start was operation with a fully assembled pick-up belt. A fully assembled pick-up belt with the wire stiffener fingers and the rubber cleating is a heavy unit, and the tester experienced some vibrational issues at the higher test speeds.

The tester will be used by Flory Industries to test belt blanks, which are belts that do not have the wire and cleats attached. Operating the tester with a lower weight belt should result in a smoother operation. Tester operation in conjunction with the hydraulic tensioner was good, but the vibration of the side plates of the tester possibly contributed to the tracking issues during operation. This problem would not exist when tensioners are fitted to an actual harvester, which has thicker side plates and a more robust frame for the belt components.

One benefit of the tester for this project was the ability to precisely control the speed of the belt during testing. This control was possible because the tester is driven by an electric motor that is controlled by a Variable Frequency Drive (VFD). The VFD allows the speed to be continuously adjusted to minimize problems during belt tensioning and initial testing.

The drive system of the tester consists of a chain drive with a tensioner sprocket. The chain was observed to have a periodic vibration that occurred during operation that potentially could be harmful to the drive over the course of time. This vibration possibly is due to the rubber flighting slightly contacting the pan that is below the belt during operation. The contact occurred at regular intervals which could possibly set up some resonance in the chain drive. An idler sprocket could possibly help dampen out the chain vibration.

### **Manual Tensioner System Testing**

During the course of testing the belt tensioner system, the manual tensioner system was tested. This system consists of threaded rod that applies force to the upper bearings. The manual tensioner is shown in Figure 3 of this report. This is the current design utilized by Flory Industries and other harvester manufacturers. However, even though it is widely used, the belt tension is usually adjusted to feel, or based off experience or performance of the belt. In some cases this leads to improper belt tensions due to neglect or inexperience. When a belt is improperly tensioned, the first indication can be heavy wear to the belt. To help address some of this lack of information, a strain gauge force transducer was used to determine the relationship between the torque applied to the adjustment bolt and the resulting belt tension. The transducer was mounted between the upper and lower shafts in the pick-up belt test rig, and a torque wrench was used to apply a specific torque value to the adjuster. The results are shown below in Figure 28 along with a linear regression line that shows the approximate relationship between torque and tension. The tension values shown are for the transducer, and the resulting belt tension would be half of this value because the transducer had all of the force passing through it. The belt tension is equal in the top and bottom strand, so two times the belt tension is the force supplied by the tensioner.

Additionally, this research helped expose a variable that can make proper tensioning somewhat difficult. During the test it was noted that the adjustment bolt had some damaged threads, and these threads were encountered during the test range. The torque needed to adjust the bolt dramatically increased when the damaged threads were encountered, and those values were subsequently left out of the results graph. (The damaged section was reached at the high range of tension in the test). This highlights the variability that can exist from harvester to harvester because a small part such as an adjuster rod can impact the torque required for proper operation. In the field, if the damage is not noticed, the operator may think that the belt is properly adjusted when it is far too loose.

The relationship of torque applied to the adjustment rod and the resulting belt tension is seen in the best fit line for the data plot in Figure 28. This relationship shows that for an increase of 1 foot-pound of torque the belt tension increases by the slope. For every 1 foot-pound of torque applied, the belt tension increases by 10.6 pounds. A calculation showing this relationship can be found in *Appendix B Design Belt Tension Specifications*. This relationship should be useful for the correct pre-tensioning of belts as they leave the current assembly line. However, several more tests of this nature should be conducted on various machines to establish a more reliable relationship for use on production equipment due to the limited scope of this project. Also, the variability in the condition of the threaded rod adjustment mechanism could be addressed by conducting multiple tests on working machines.

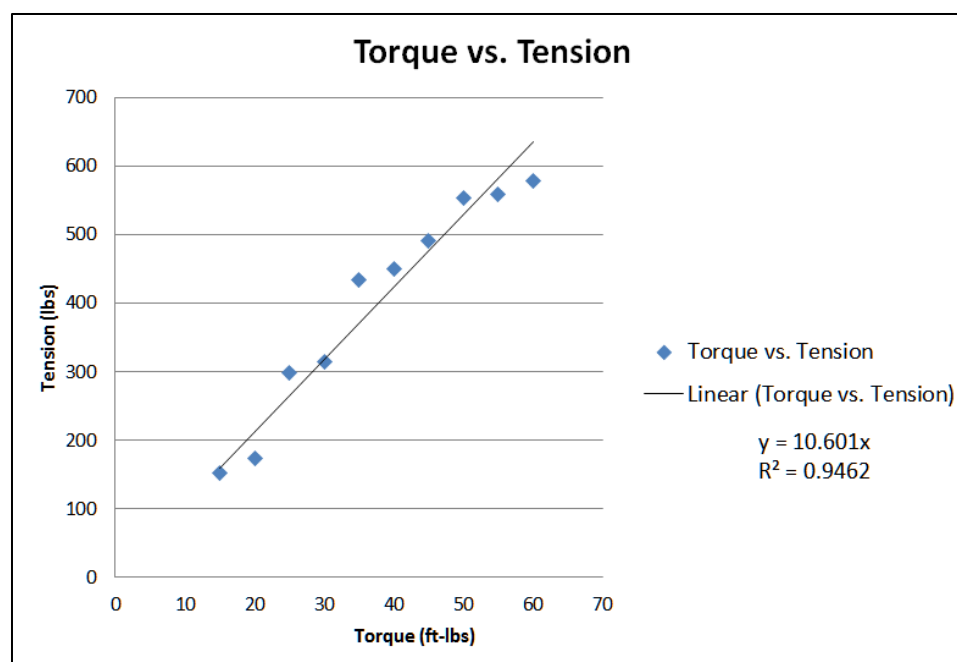

Figure 28. Manual Adjustment Torque vs. Tension Curve.

A calculation was done to determine the theoretical torque vs. tension relationship and it is located in *Appendix B Adjuster Bolt Torque and Force Theoretical Relationship*. The results of this calculation compared very nicely to the observed data. The theoretical slope was 13.63 lbs per ft-lb of tension. The difference between the two can easily be attributed to uncertain friction coefficients, as well as other friction in the system besides the threads and collar.

When using a manual tensioning mechanism, attention must be given to the condition of the adjustment components to ensure consistent, proper tensioning of the belt. Additionally, to achieve the longest possible pick-up belt life the lower roller cleaned of accumulated dirt and the tension checked daily. While tedious, this is the best way to ensure a long belt life.

### **Belt Tracking Concerns with Tensioner**

The primary issue facing a successful tensioner design is the challenge of keeping the belt centered in the machine. When the tension is not correct on each side the belt has a tendency to pull to the side of the unit. This can cause premature wear on the belt and decrease its service life. When testing the belt with the tensioner it was evident that this would also be an issue with a tensioner system. Initially the belt was adjusted to where it was tracking correctly in the center of the shafts, but after several minutes of operation with simulated obstructions being passed behind the belt, the belt pulled toward the fixed side of the system. This is due to the fact that the side with the tensioner was seeing small increases in tension as the dynamic system responded to the obstructions, and this small tension difference slowly moved the belt to the opposite side of the tester. Even the addition of a second tensioner would not completely solve this problem because the amount of obstructions that a certain side of a harvester encounters is not necessarily consistent and belt misalignment could still occur. With the implementation of a system such as a tensioning mechanism would come many hours of in-field operation to determine if the belt would remain satisfactorily centered.

### **Belt Guidance Possibilities**

There are several solutions to the belt tracking issue that comes along with a dynamic tensioning system that could be implemented in a pick-up belt system.

The first type of belt tracking device is a crowned pulley or roller shaft. A crowned roller has a flat center section that is generally one half of the overall width, and slightly tapered sections that occur on the outside quarters of the roller. The taper on the roller creates a resultant force when the belt becomes misaligned to one direction or the other, and this result force drives the belt back the center where the forces equalize. This type of alignment system is effective but allows for a constant drifting motion back and forth as system conditions change. An issue that would need to be addressed when using a



crowned roller is the steel angel pieces that are used as mounting pieces on many pick-up belts. As a steel piece passes over a crowned roller there are excess stresses placed on the joints which can lead to premature failure. To minimize this effect the crown would need to be minimized while still providing adequate guidance. An example of a crowned roller design is shown below in Figure 29.

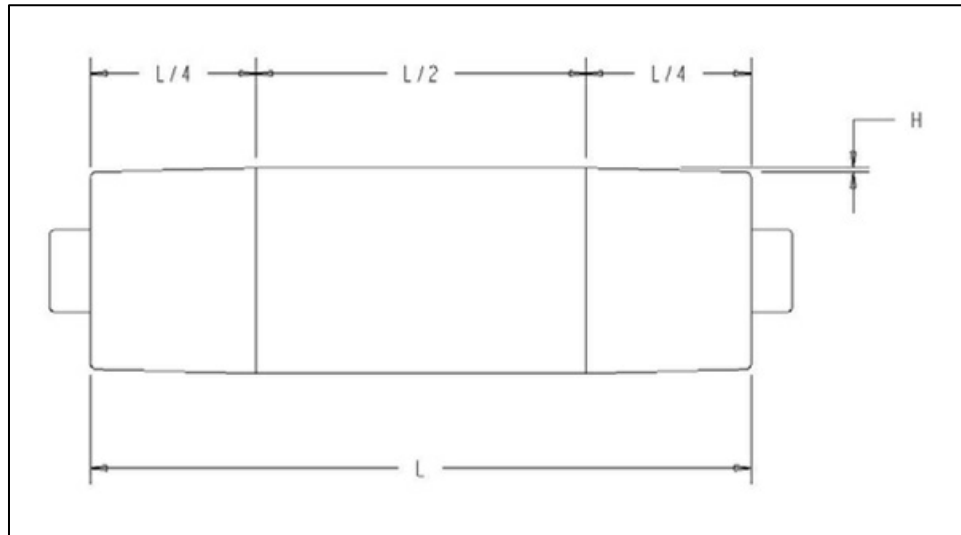

Figure 29. Crowned Roller Details.

The second type of belt tracking device is the v-guide tracking system. In this type of tracking device a guide strip of belt material is attached to the underside of the belt and it runs in a groove that keeps the belt centered (Figure 30). This type of centering device is very effective and can high higher side loading than the crowned roller type. Another advantage of this system is that it uses a flat roller that has an index machined in the center where the guide strip is to ride. This eliminates the concern of the excess stress placed upon the metal angle pieces while providing an excellent tracking solution.

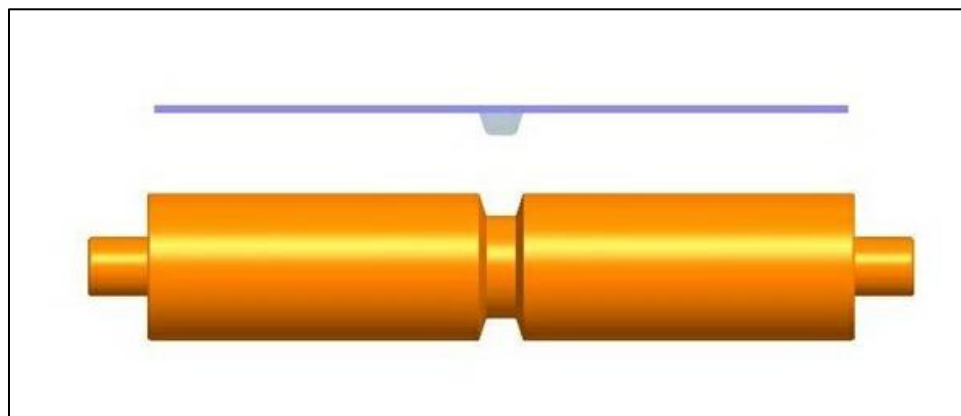

Figure 30. V-Groove Guidance System.

These belt guidance solutions are offered as design recommendations that could accompany the implementation of a pick-up belt tensioning device. With a groove design both the upper and lower roller would need to be redesigned, with consideration given the increased bending stress in the center of the shaft due to the groove.

### **Final Conclusion**

This project began with the goal of producing a working tensioner prototype that had been tested. This goal has been met, and several important observations were made along the way. The hydraulic tensioner was successful at allowing obstructions to pass through the system and keeping the force constant, but the belt tracking issue will have to be addressed in the next prototype. The tensioner showed potential for adaption to a harvester with some adjustments to the harvester hydraulic system and some mounting modifications.

## REFERENCES

1. 4Physics. 2012. Hooke's Law. [www.4physics.com](http://www.4physics.com). Referenced January 2012.
2. Budynas, R.G. and J.K. Nisbett. 2008. Shigley's Mechanical Engineering Design, Ninth Edition. McGraw-Hill, New York, NY. 1109 p.
3. Eaton. 2008. Industrial Hydraulics Manual. Eaton Hydraulics Operations Training Services, Maumee, OH. 642 p.
4. Flory Industries. 2012. Flory Industries 850 PTO Harvester Model Page. [www.goflory.com](http://www.goflory.com). Referenced January 2012.
5. Korane, Kenneth J. 2004. SPEED LIMITS: Relating flow velocity to hydraulic performance. [www.machinedesign.com](http://www.machinedesign.com). Referenced May 2012.
6. Lesjofors Springs. 2012. Gas Springs. [www.lesjoforsab.com](http://www.lesjoforsab.com). Referenced January 2012.
7. McMaster Carr. Compression Springs. [www.mcmaster.com](http://www.mcmaster.com). Referenced March 2012.
8. Titan Gas Springs. Titan Nitrided Gas Springs. [www.titaneps.com](http://www.titaneps.com). Referenced January 2012.
9. Vulcan Springs. 2012. Conforce ® Constant Force Springs. [www.vulcansprings.com](http://www.vulcansprings.com). Referenced January 2012.

**APPENDIX A**

**HOW PROJECT MEETS REQUIREMENTS FOR THE BRAE  
MAJOR**

## **Major Design Experience**

The BRAE senior project must incorporate a major design experience. Design is the process of devising a system, component, or process to meet specific needs. The design process typically includes fundamental elements as outline below. This project addresses these issues as follows.

### **Establishment of Objectives and Criteria**

Project objective and criteria are established to meet the needs and expectations of Flory Industries. This includes any design elements or revisions of their request.

### **Synthesis and Analysis**

This project incorporates design elements from many mechanical systems classes, as well as evaluations such as shear stress, hydraulic flow, and belt tension. Also included is Finite Elemental Analysis of various components.

### **Construction, Testing, and Evaluation**

The hydraulic tensioner of the project was designed, constructed, tested, and evaluated over the course of this project.

### **Incorporation of Applicable Engineering Standards**

This project utilizes AISC standards for allowable stresses as well as SAE specifications for allowable stress in steel bolts.

## **Capstone Design Experience**

The BRAE senior project is an engineering design project based on the knowledge and skills acquired in earlier coursework (Major, Support, and/or GE courses). This project incorporates knowledge/skills from these key courses.

- BRAE 129 Lab Skills / Safety
- BRAE 133 Engineering Graphics
- BRAE 151 AutoCAD
- BRAE 152 SolidWorks
- BRAE 234 Mechanical Systems
- BRAE 421/422 Equipment Engineering
- ME 211/212 Engineering Statics / Dynamics
- CE 204/207 Strength of Materials
- ENGL 149 Technical Writing

## **Design Parameters and Constraints**

This project addresses a significant number of the categories listed below.

### Physical

The tensioner system must adapt to the existing belt tester, with the long range goal of mounting to a production harvester.

### Economic

The cost of project must meet the expectations of the Flory Industries Engineering Department, with the goal of economic manufacturability.

### Environmental

The goal of this project is to increase belt life, which will reduce the belt material needed per harvester during the life of the machine.

### Sustainability

N/A

### Manufacturability

The results of this project should be adaptable to large scale production.

### Health and Safety

This project incorporates the necessary equipment to ensure operator and crop safety.

### Ethical

The intent of this project is to not infringe on any existing patents or designs.

### Social

N/A

### Political

N/A

### Aesthetic

This project must meet the high standards of the BRAE department.

### Other

N/A

**APPENDIX B**  
**DESIGN CALCULATIONS**



## Design Belt Tension Specification

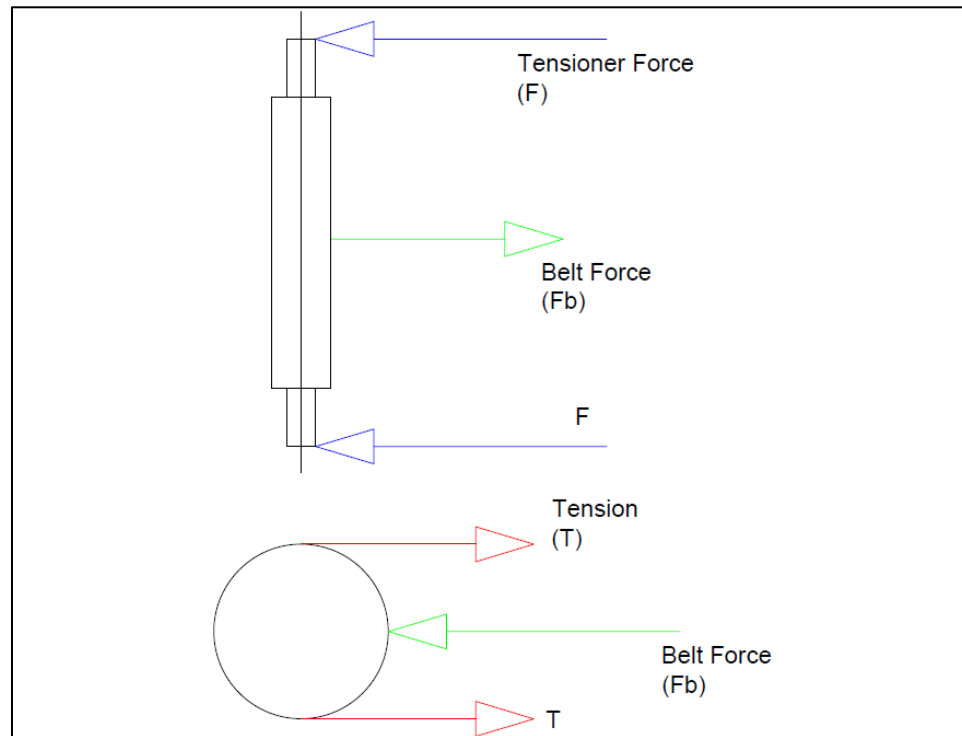

Figure 31. Belt Tension Diagram.

### Adjuster Sum of Forces

$$\text{Sum of } F = 2F - Fb = 0$$

$$2F = Fb$$

### Belt Sum of Forces

$$\text{Sum of } F = -2T + Fb = 0$$

$$T = \frac{Fb}{2}$$

### Combine

$$T = \frac{2F}{2} = F$$

This shows that the force supplied by the tensioner,  $F$ , is equal to the resulting belt tension,  $T$ . For this project the design belt tension range is 800 lbs to 1500 lbs. This range was used for all other calculations.

## Cylinder Sizing

For the cylinder sizing calculation a working line pressure of 2000 psi was assumed.

### Equations

$$Pressure = \frac{Force}{Area}$$

$$Area = \frac{\pi D^2}{4}$$

$$Design Force = 1500 \text{ lbs}$$

$$Area = \frac{1500 \text{ lbs}}{2000 \text{ psi}}$$

$$A = 0.75 \text{ in}^2 = \frac{\pi D^2}{4}$$

$$D = 0.98 \text{ in} \Rightarrow 1.00 \text{ in}$$

A 1.5 inch diameter cylinder was readily available for this project so it was used instead of the smaller 1 inch cylinder. With the 1.5 inch cylinder the maximum available force is greater than the smaller cylinder so it meets and exceeds the requirements.

### Belt Stretch Calculation

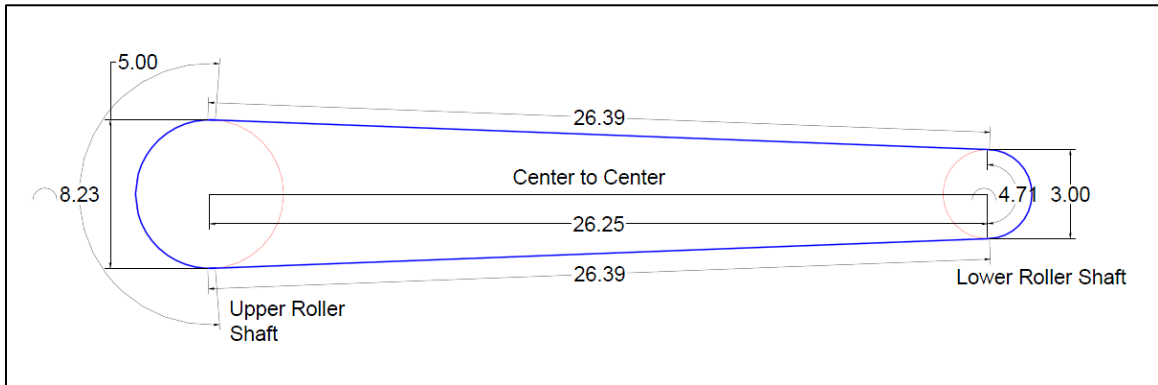

Figure 32. Belt Length Diagram.

$$\text{Total belt length} = 2 * 26.39\text{in} + 8.23\text{in} + 4.71\text{in} = 65.72 \text{ inches}$$

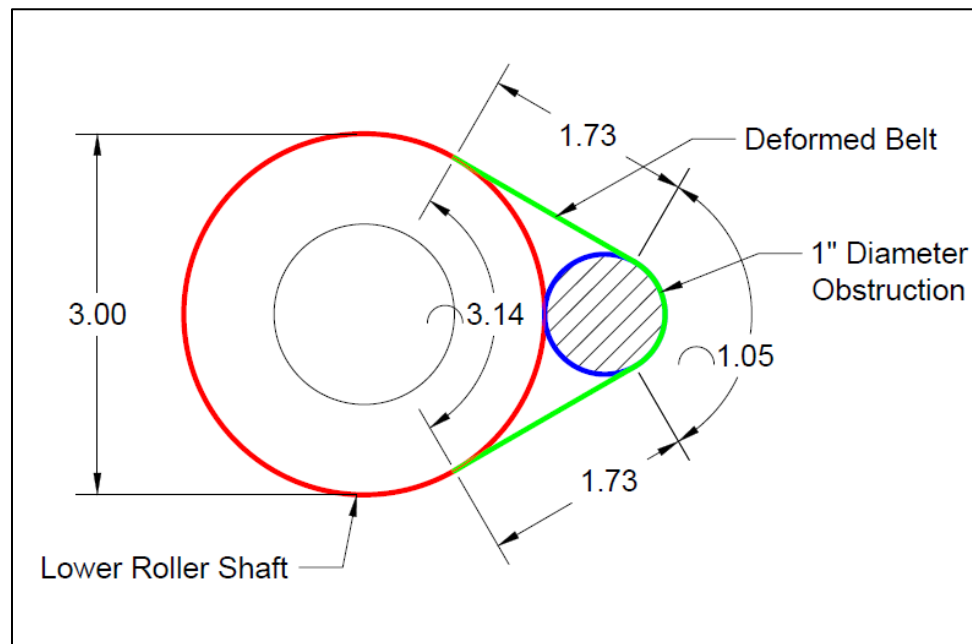

Figure 33. Deformed Belt Diagram.

When a fixed pick-up system encounters an obstacle such as a rock or dirt build up, the belt stretches to accommodate the obstruction. The diagram in Figure 33 shows the resulting belt stretch for a 1" diameter obstruction. The green line represents the deformed portion of the belt.

$$\text{Belt Stretch} = (2 * 1.73 \text{ in}) + 1.05 \text{ in} - 3.14 \text{ in}$$

$$\text{Belt Stretch} = 1.37 \text{ inches}$$

$$\sigma = E * \epsilon$$

Where:

$E = 30,000 \text{ lbs per inch (piw) of belt width}$

$$\epsilon = \frac{\Delta l}{l_o} = \frac{1.37in}{65.72in} = 0.0208 \% \text{ Elongation}$$

*Obstruction is 1 inch wide*

$$\sigma = 18,606 \text{ piw} * 1 \text{ in wide} * .0208$$

$$\sigma = 387 \text{ lbs}$$

This belt stretch value is an approximate due to the complex nature of the rubber belt and the non-round obstacles encountered in the field. However, it is a realistic value to use for the evaluation of the pick-up belt system. The resulting force increase on the strip of belt encountering the obstruction is approximately 387 pounds, which in some cases is a local increase in belt tension of 50% over the initial value. This has a dramatic effect when the obstruction occurs near the edge of the belt.

Fluid Flow during Deflection

*Cylinder diameter = 1.5 inch*

*Obstruction diameter = 1.0 inch = piston deflection*

*Volume = Area \* Deflection*

$$V = \frac{\pi D^2}{4} * Deflection$$

$$V = 1.77 \text{ in}^3$$

This is the volume displaced during deflection due to a 1 inch obstruction. This is the fluid that must flow through the relieve valve, as well as the volume that must flow from the supply side of the system to extend the cylinder.

### Fluid Velocity during Deflection

$$\text{Shaft Speed} = 250 \text{ RPM}$$

$$\text{Time for 1 rotation} = \frac{1}{250 \text{ RPM}} = 0.004 \frac{\text{min}}{\text{rot}} * \left| \frac{60 \text{ sec}}{\text{min}} \right| = 0.24 \frac{\text{sec}}{\text{rot}}$$

Displacement occurs over ½ of a revolution of the shaft.

$$\text{Disp. Time} = \frac{1}{2} * 0.24 \text{ sec}$$

$$DT = .12 \text{ sec}$$

$$\text{Flow} = Q = \frac{V}{T}$$

$$Q = \frac{1.77 \text{ in}^3}{0.12 \text{ sec}} = 14.75 \frac{\text{in}^3}{\text{sec}}$$

Fluid speed through 0.25 hose / orifice:

$$Q = \text{Velocity} * \text{Area}$$

$$V = \frac{Q}{A} = \frac{14.75 \text{ in}^3}{\frac{\pi(.25)^2}{4}} = 300 \frac{\text{in}}{\text{sec}} = 25 \frac{\text{ft}}{\text{sec}}$$

The fluid velocity is near the upper end of the allowable limits during deflection. A rule of thumb for sizing lines and orifices to avoid excess pressure loss is to keep the fluid velocity under 25-30 fps (ft per sec).

Another principle to consider is the time it takes for the hydraulic pressure relief valve to open during a pressure increase. Kenneth Korane (2004) explains in the MachineDesign.com article *Speed Limits: Relating flow velocity to hydraulic performance* that a relief valve with a 50 millisecond response setting opens and begins to flow 12 ms after the flow requirement is initiated. During this time the system must absorb the pressure increase. For a fluid velocity of 300 in/sec (25 fps) and an initial pressure setting of 100 psi with a valve opening time of 12 ms, the pressure spike is 1970 psi. However, the system modeled in his article was an instantaneous situation where fluid was flowing at a continuous velocity of 25 fps was stopped suddenly. The hydraulic tensioner model in this project has a pressure build-up over ½ of the shaft rotation (0.12 sec) so it will be less dramatic. However, the principle still remains, and testing may need to be done to evaluate whether or not the pressure spike due to fluid velocity is significant in this very complex dynamic system.

Spring Solid Safe CalculationSpring Specifications

$$\text{Wire Dia} = d = 0.375 \text{ in}$$

$$L_o = 8 \text{ in} \quad L_c = 5.57 \text{ in}$$

$$OD = 2.187 \text{ in}$$

$$\text{Mean dia} = D = OD - d = 1.812 \text{ in}$$

$$\text{Spring rate, } k = 371.8 \frac{\text{lb}}{\text{in}}$$

$$\text{Deflection force} = k * (L_o - L_c) = 371.8 \frac{\text{lb}}{\text{in}} * 2.43 \text{ in}$$

$$F = 903.5 \text{ lbs}$$

$$\tau_{max} = \frac{k_s 8FD}{\pi d^3}$$

Where:

$$k_s = \frac{2c + 1}{2c} \quad c = \frac{D}{d} = \frac{1.812 \text{ in}}{0.375 \text{ in}} = 4.832$$

$$k_s = 1.1035$$

$$\tau_{max} = \frac{1.1035 * 8 * 903.5 \text{ lb} * 1.812 \text{ in}}{\pi 0.375^3} = 87.24 \text{ ksi}$$

$$\text{Ultimate Strength} = S_{ut} = \frac{A}{d^m}$$

Where:

$$A = 147 \text{ kpsi} \quad m = 0.187 \quad d = 0.375 \text{ in}$$

$$S_{ut} = \frac{147 \text{ kpsi}}{(0.375 \text{ in})^{0.187}} = 176.6 \text{ ksi}$$

$$S_{all} = 0.45 * S_{ut} = 78.5 \text{ ksi}$$

$$\tau_{max} > S_{ut} \Rightarrow \text{Spring not solid safe}$$

Design should take into account that this spring is not solid safe and care be taken that the spring not be compressed to its completely collapsed length.

### Upper Cylinder Mount Weld Analysis

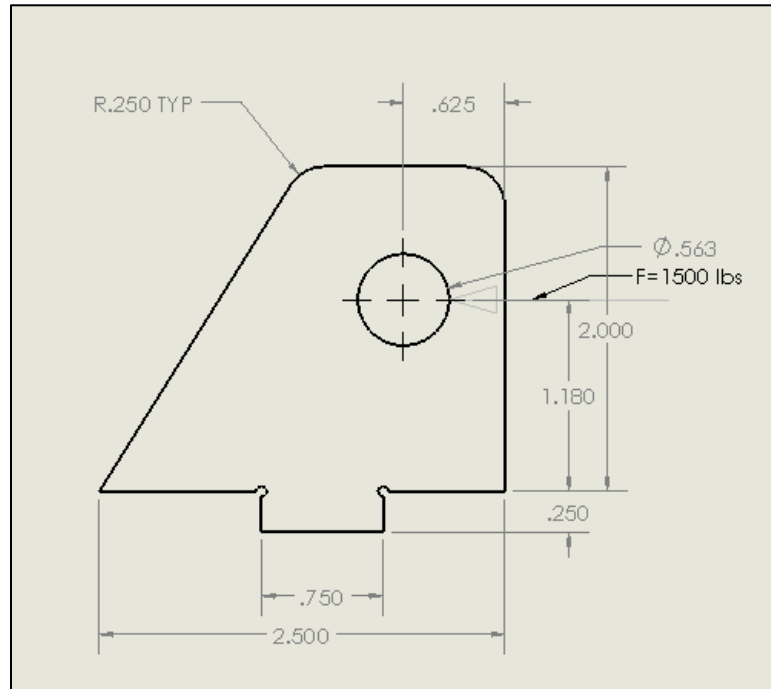

Figure 34. Upper Cylinder Mount Weld Analysis.

*Weld is 0.25 in by 2.5 in on both sides*

$$h = 0.25 \text{ in} \quad l = 2.5 \text{ in} \quad F = 1500 \text{ lbs}$$

*There is primary and secondary shear stress in the weld*

$$\tau' = \frac{F}{2 * 0.707hl} = \frac{1500 \text{ lb}}{2 * 0.707 * 0.25\text{in} * 2.5\text{in}} = 1.697 \text{ ksi}$$

$$\tau'' = \frac{Mc}{0.707h * l * I_u} = \frac{1500\text{lb} * 1.18\text{in} * \frac{2.5\text{in}}{2}}{.707 * .25\text{in} * \frac{2.5\text{in}^3}{6}} = 4.80 \text{ ksi}$$

$$\tau_{max} = ((\tau')^2 + (\tau'')^2)^{1/2} = 4.86 \text{ ksi}$$

$$\tau_{all} = 0.40(S_y) = 0.40 * 62 \text{ ksi} = 24.8 \text{ ksi}$$

$$FOS = \frac{\tau_{all}}{\tau_{max}} = \frac{24.8 \text{ ksi}}{4.86 \text{ ksi}} = 4.86$$

$\tau_{all}$  and  $I$  equations from Shigley's Mechanical Engineering Design



Cylinder Mount Bolt Shear

*Cylinder mount bolts in double shear due to clevis style mount*

*bolt = 0.500 diameter nominal      mean diameter = 0.450 in*

*tensile area = 0.1419 in<sup>2</sup>*

$$\tau_{max} = \frac{F}{2A} = \frac{1500 \text{ lb}}{2 * 0.1419 \text{ in}^2} = 5.29 \text{ ksi}$$

$$\tau_{all} = 0.57(S_y) = 0.57 * 120 \text{ ksi} = 68.4 \text{ ksi}$$

*S<sub>y</sub> from Shigley's*

*Bolts are sufficient in shear.*

*The bending effect is negligible due to the clevis mount.*

Upper Adjuster Plate FEA Analysis

Figure 35. Upper Adjuster Plate FOS Plot.

This stress analysis was completed with a load of 1500 pounds placed on an area the size of the adjustment nut. The resulting FOS plot shows a minimum FOS of approximately 4.

Adjuster Bolt Torque and Force Theoretical Relationship

*Raising Torque:*

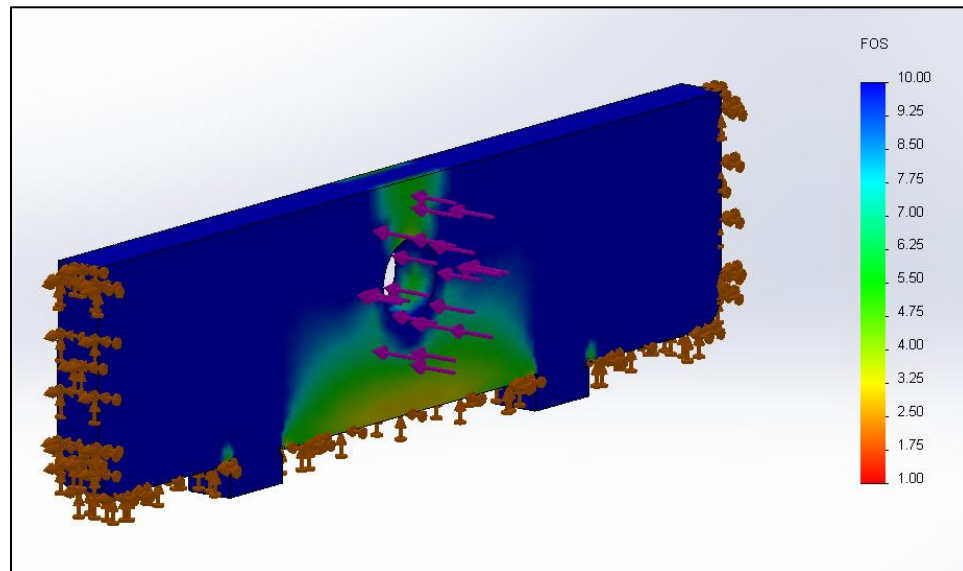
$$T = \frac{F * d_m(l + \pi\mu d_m \sec(\alpha))}{2(\pi d_m + \mu l \sec(\alpha))}$$

*Where:*

$$\text{Bolt: } 0.75 \text{ NC} \quad d_m = 0.6850 \text{ in} \quad l = 0.10 \text{ in}$$

$$\mu = \text{friction} = 0.15 \quad \alpha = 30^\circ \quad \sec\alpha = 1.155$$

$$T = F_{dm}(0.0746 \text{ in})$$

*Collar Friction:*

$$T_{\text{collar}} = \frac{\mu F d_c}{2}$$

*Where:*

$$F = \text{Force being raised} \quad \mu = \text{friction} = 0.15$$

$$d_c = \frac{d_{\text{outer}} + d_{\text{inner}}}{2} = \frac{1.125 \text{ in} + 0.75 \text{ in}}{2} = 0.9375 \text{ in}$$

$$T(\text{in} - \text{lbs}) = F(0.0703 \text{ in})$$

$$T(\text{in} - \text{lbs}) = F(0.0746 \text{ in} + 0.0703 \text{ in}) = F(0.147 \text{ in})$$

$$F = T(6.82)$$

*There are two tensioners for the belt:*

$$F = T(13.6)$$

This is very near the measured value of 10.61 lbs of tension for 1 ft-lb of torque. The difference can be attributed to not knowing the exact friction values for the theoretical equations.

**APPENDIX C**

**CONSTRUCTION DRAWINGS**

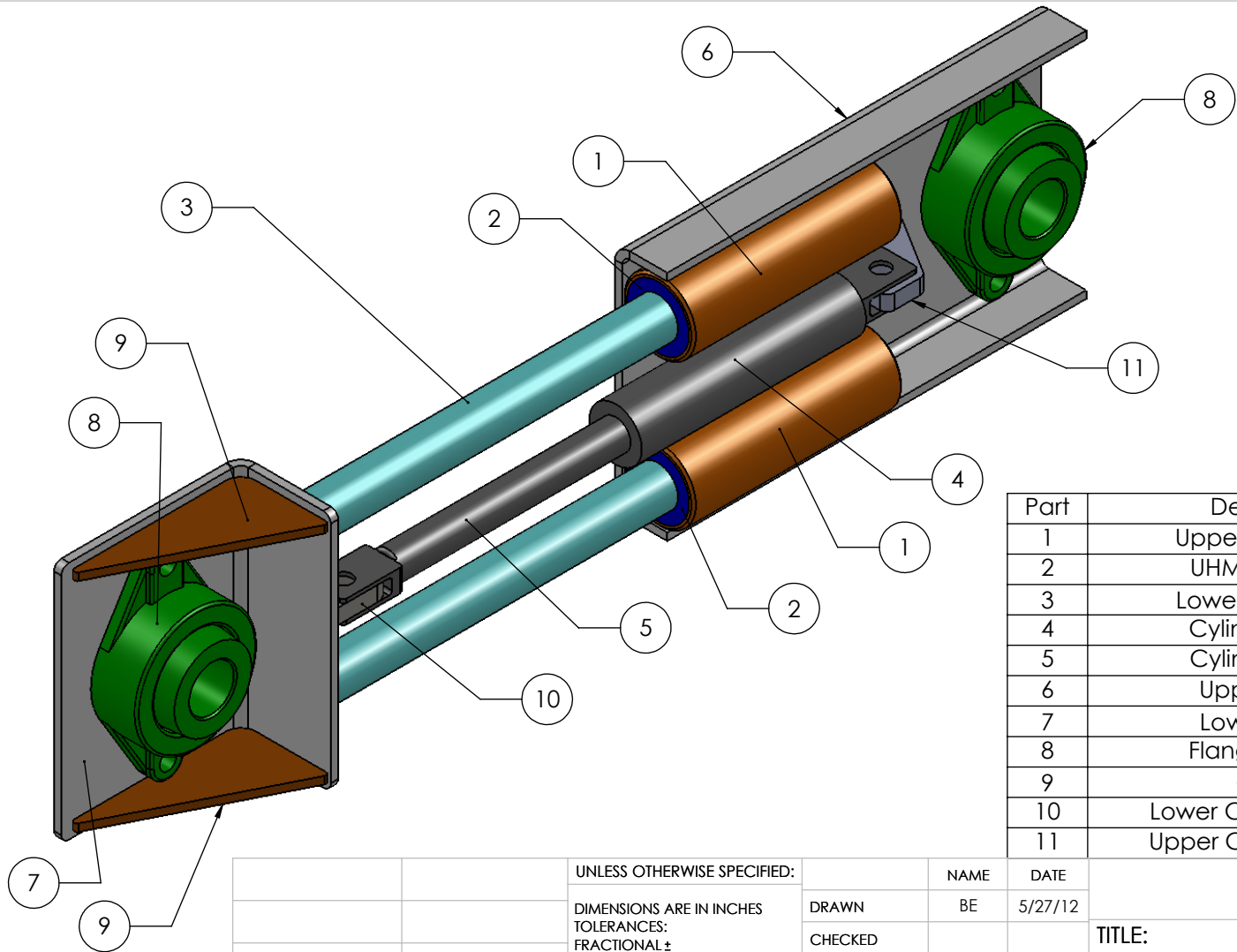

Part	Description
1	Upper Slider Tube
2	UHMW Bushing
3	Lower Slider Tube
4	Cylinder Upper
5	Cylinder Lower
6	Upper Mount
7	Lower Mount
8	Flange Bearing
9	Gusset
10	Lower Cylinder Mount
11	Upper Cylinder Mount

		UNLESS OTHERWISE SPECIFIED:		NAME	DATE
		DIMENSIONS ARE IN INCHES	DRAWN	BE	5/27/12
		TOLERANCES:	CHECKED		
		FRACTIONAL ±	ENG APPR.		
		ANGULAR: MACH ± BEND ±	MFG APPR.		
		TWO PLACE DECIMAL ±			
		THREE PLACE DECIMAL ±			
		INTERPRET GEOMETRIC TOLERANCING PER:	Q.A.		
		MATERIAL	COMMENTS:		
		FINISH			
NEXT ASSY	USED ON				
	Hydraulic Tensioner				
		DO NOT SCALE DRAWING			

**PROPRIETARY AND CONFIDENTIAL**  
 THE INFORMATION CONTAINED IN THIS DRAWING IS THE SOLE PROPERTY OF <INSERT COMPANY NAME HERE>. ANY REPRODUCTION IN PART OR AS A WHOLE WITHOUT THE WRITTEN PERMISSION OF <INSERT COMPANY NAME HERE> IS PROHIBITED.

TITLE:	
SIZE	DWG. NO.
<b>A</b>	Tube Hydraulic Assy
SCALE: 1:12	SHEET 1 OF 10

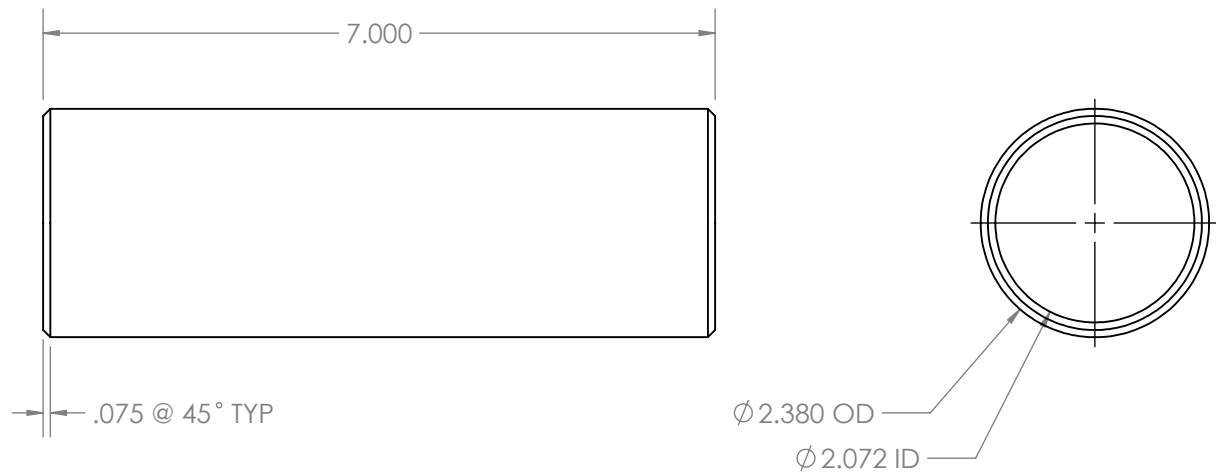

**PROPRIETARY AND CONFIDENTIAL**  
 THE INFORMATION CONTAINED IN THIS DRAWING IS THE SOLE PROPERTY OF <INSERT COMPANY NAME HERE>. ANY REPRODUCTION IN PART OR AS A WHOLE WITHOUT THE WRITTEN PERMISSION OF <INSERT COMPANY NAME HERE> IS PROHIBITED.

**2X per assy		UNLESS OTHERWISE SPECIFIED:		NAME	DATE		
		DIMENSIONS ARE IN INCHES	DRAWN	BE	5/27/12	TITLE:	
		TOLERANCES:	CHECKED			Upper Slider Tube	
		FRACTIONAL ±	ENG APPR.			SIZE DWG. NO.	
		ANGULAR: MACH ± BEND ±	MFG APPR.			A	
		TWO PLACE DECIMAL ±	Q.A.			SCALE: 1:4 SHEET 2 OF 10	
		THREE PLACE DECIMAL ±	COMMENTS:				
		INTERPRET GEOMETRIC TOLERANCING PER:					
		MATERIAL					
		2 in sch 40					
NEXT ASSY	USED ON	FINISH					
	Hydraulic Tensioner	DO NOT SCALE DRAWING					

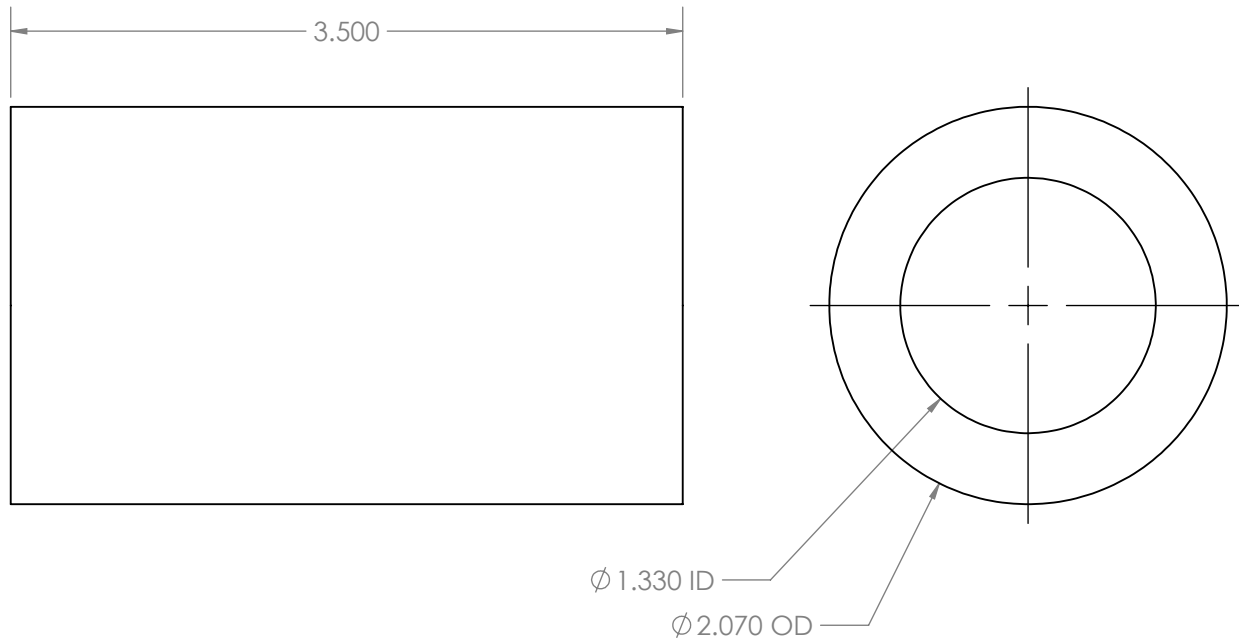

\*McMaster Carr Part # 8701K51 - Impact Resistant UHMW Polyethylene Rod  
2-1/4" Diameter, 2' length

\*\*Machine to dimensions noted

<b>**4X per assy</b>			UNLESS OTHERWISE SPECIFIED:	NAME	DATE		
			DIMENSIONS ARE IN INCHES	DRAWN	BE	5/27/12	<b>TITLE:</b>  UHMW Bushing
			TOLERANCES:	CHECKED			
			FRACTIONAL ±	ENG APPR.			
			ANGULAR: MACH ±    BEND ±	MFG APPR.			
		TWO PLACE DECIMAL ±	Q.A.			<b>SIZE</b> DWG. NO.	
		THREE PLACE DECIMAL ±	COMMENTS:				
		INTERPRET GEOMETRIC TOLERANCING PER:				<b>A</b>	SCALE: 1:2    SHEET 3 OF 10
		MATERIAL					
		UHMW					
		FINISH					
NEXT ASSY	USED ON						
	Hydraulic Tensioner						
		DO NOT SCALE DRAWING					

**PROPRIETARY AND CONFIDENTIAL**  
THE INFORMATION CONTAINED IN THIS DRAWING IS THE SOLE PROPERTY OF <INSERT COMPANY NAME HERE>. ANY REPRODUCTION IN PART OR AS A WHOLE WITHOUT THE WRITTEN PERMISSION OF <INSERT COMPANY NAME HERE> IS PROHIBITED.

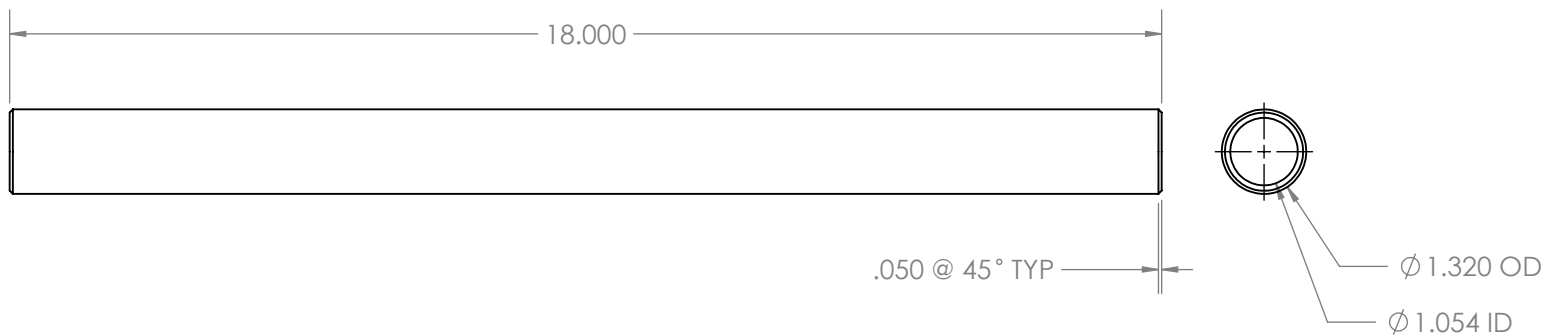

**PROPRIETARY AND CONFIDENTIAL**  
 THE INFORMATION CONTAINED IN THIS DRAWING IS THE SOLE PROPERTY OF <INSERT COMPANY NAME HERE>. ANY REPRODUCTION IN PART OR AS A WHOLE WITHOUT THE WRITTEN PERMISSION OF <INSERT COMPANY NAME HERE> IS PROHIBITED.

**2X per assy		UNLESS OTHERWISE SPECIFIED:		NAME	DATE	TITLE: Lower Slider Tube
		DIMENSIONS ARE IN INCHES	DRAWN	BE	5/27/12	
		TOLERANCES: FRACTIONAL ±	CHECKED			
		ANGULAR: MACH ± BEND ±	ENG APPR.			
		TWO PLACE DECIMAL ±	MFG APPR.			SIZE DWG. NO. <b>A</b>
		THREE PLACE DECIMAL ±	Q.A.			
		INTERPRET GEOMETRIC TOLERANCING PER:	COMMENTS:			SCALE: 1:8 SHEET 4 OF 10
		MATERIAL 1 in sch 40				
NEXT ASSY	USED ON	FINISH				
Hydraulic Tensioner		DO NOT SCALE DRAWING				



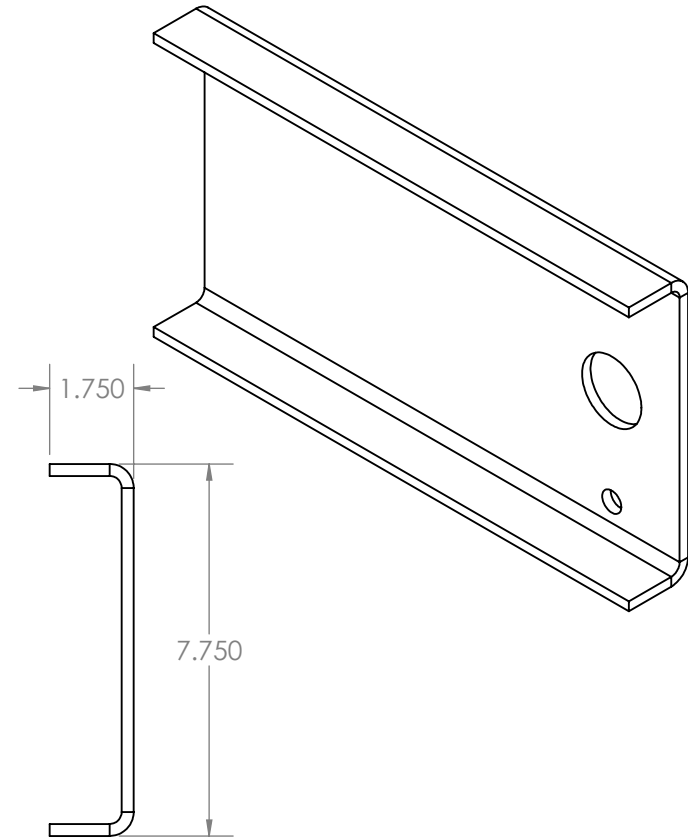
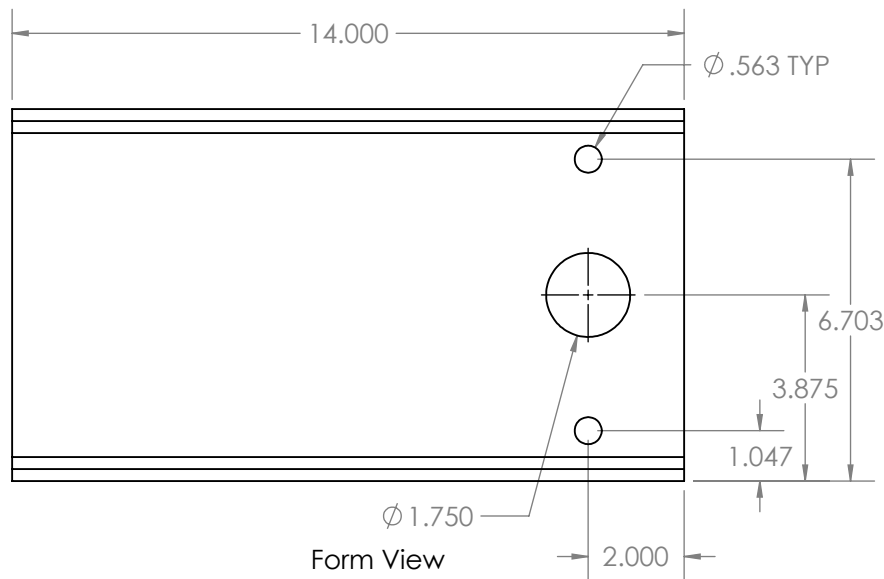

**PROPRIETARY AND CONFIDENTIAL**  
 THE INFORMATION CONTAINED IN THIS DRAWING IS THE SOLE PROPERTY OF <INSERT COMPANY NAME HERE>. ANY REPRODUCTION IN PART OR AS A WHOLE WITHOUT THE WRITTEN PERMISSION OF <INSERT COMPANY NAME HERE> IS PROHIBITED.

**1X per assy		UNLESS OTHERWISE SPECIFIED:	NAME	DATE	TITLE:  Upper Mount		
		DIMENSIONS ARE IN INCHES	DRAWN	BE			5/27/12
		TOLERANCES:	CHECKED				
		FRACTIONAL ±	ENG APPR.				
		ANGULAR: MACH ± BEND ±	MFG APPR.				
		TWO PLACE DECIMAL ±	Q.A.			SIZE DWG. NO.	
		THREE PLACE DECIMAL ±	COMMENTS:				
		INTERPRET GEOMETRIC TOLERANCING PER:				SCALE: 1:8 SHEET 5 OF 10	
		MATERIAL					
NEXT ASSY	USED ON	FINISH					
	Hydraulic Tensioner	DO NOT SCALE DRAWING					

5

4

3

2

1

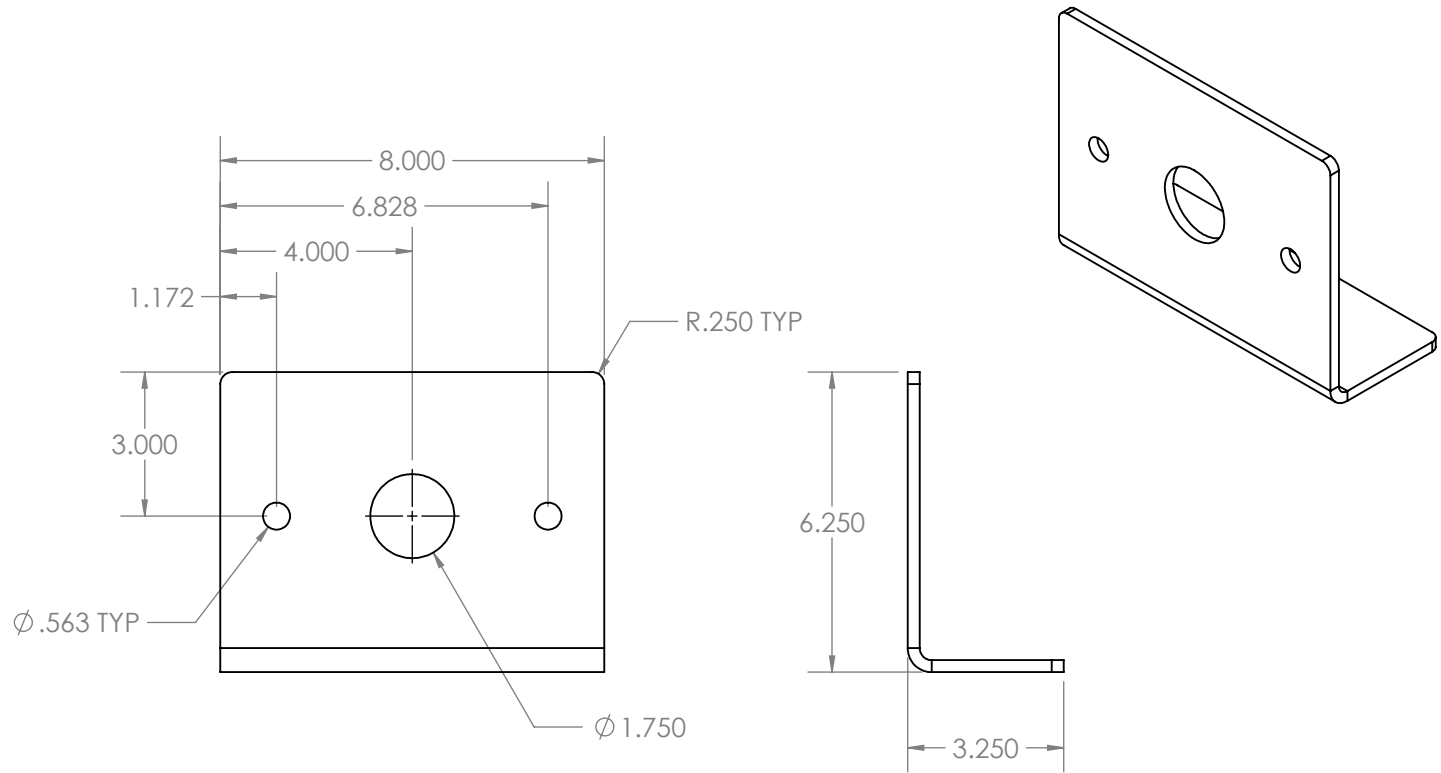

**1X per assy		UNLESS OTHERWISE SPECIFIED:	NAME	DATE	TITLE:  Lower Mount		
		DIMENSIONS ARE IN INCHES	DRAWN	BE			5/27/12
		TOLERANCES:	CHECKED				
		FRACTIONAL ±	ENG APPR.				
		ANGULAR: MACH ± BEND ±	MFG APPR.				
		TWO PLACE DECIMAL ±	Q.A.			SIZE DWG. NO.	
		THREE PLACE DECIMAL ±	COMMENTS:				
		INTERPRET GEOMETRIC TOLERANCING PER:				SCALE: 1:4 SHEET 6 OF 10	
		MATERIAL					
		0.25 HR Plate					
NEXT ASSY	USED ON	FINISH					
	Hydraulic Tensioner	DO NOT SCALE DRAWING					

**PROPRIETARY AND CONFIDENTIAL**  
 THE INFORMATION CONTAINED IN THIS DRAWING IS THE SOLE PROPERTY OF <INSERT COMPANY NAME HERE>. ANY REPRODUCTION IN PART OR AS A WHOLE WITHOUT THE WRITTEN PERMISSION OF <INSERT COMPANY NAME HERE> IS PROHIBITED.

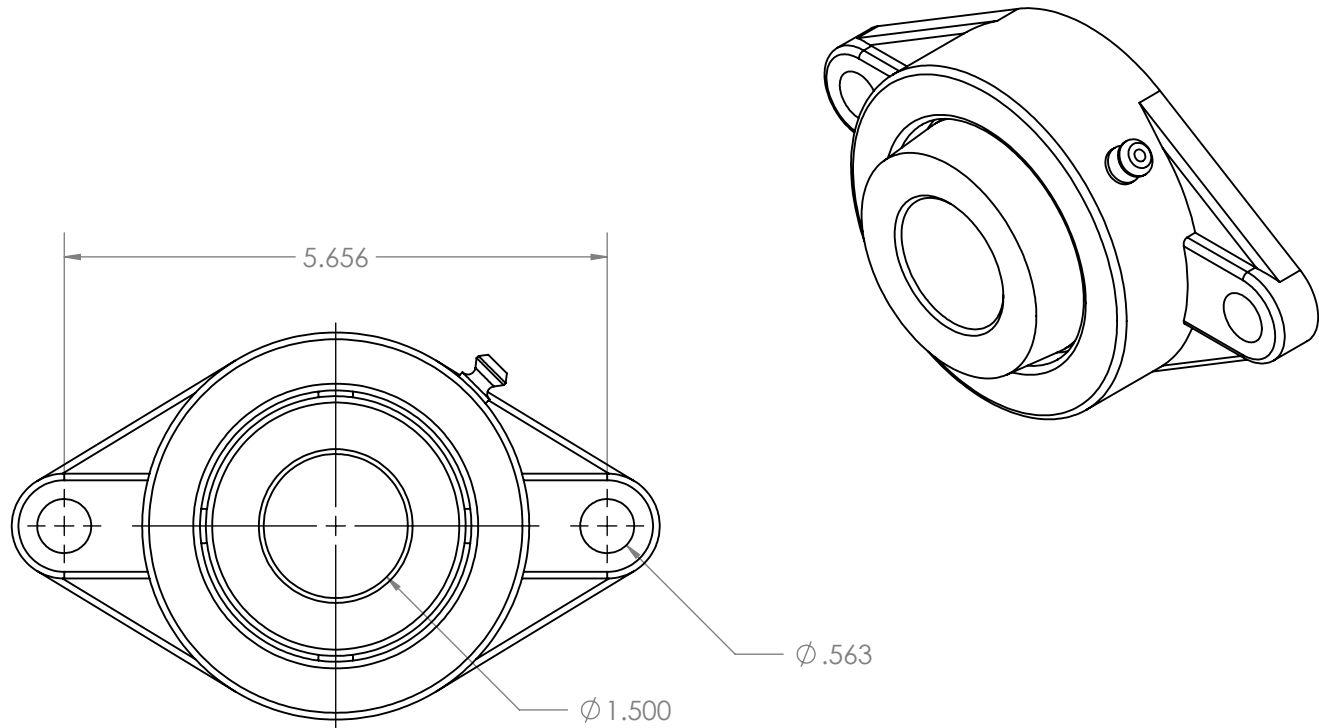

\*Flory part # FLC2108

**2X per assy	UNLESS OTHERWISE SPECIFIED:		NAME	DATE	TITLE:  Timken Flange Bearing
	DIMENSIONS ARE IN INCHES TOLERANCES: FRACTIONAL ± ANGULAR: MACH ± BEND ± TWO PLACE DECIMAL ± THREE PLACE DECIMAL ±		DRAWN	BE 5/27/12	
	INTERPRET GEOMETRIC TOLERANCING PER:		CHECKED		SIZE DWG. NO. <b>A</b>
	MATERIAL		ENG APPR.		
	FINISH		MFG APPR.		SCALE: 1:2 SHEET 7 OF 10
NEXT ASSY	USED ON	DO NOT SCALE DRAWING	Q.A.	COMMENTS:	
Hydraulic Tensioner					

**PROPRIETARY AND CONFIDENTIAL**  
 THE INFORMATION CONTAINED IN THIS DRAWING IS THE SOLE PROPERTY OF <INSERT COMPANY NAME HERE>. ANY REPRODUCTION IN PART OR AS A WHOLE WITHOUT THE WRITTEN PERMISSION OF <INSERT COMPANY NAME HERE> IS PROHIBITED.

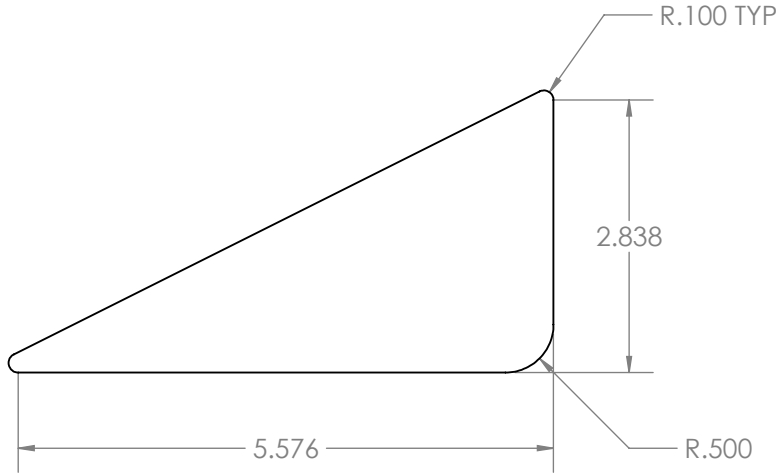
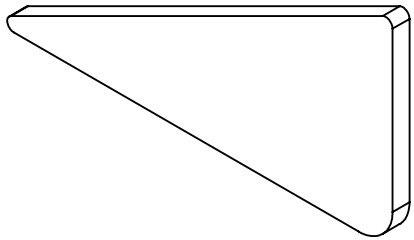

**PROPRIETARY AND CONFIDENTIAL**  
 THE INFORMATION CONTAINED IN THIS DRAWING IS THE SOLE PROPERTY OF <INSERT COMPANY NAME HERE>. ANY REPRODUCTION IN PART OR AS A WHOLE WITHOUT THE WRITTEN PERMISSION OF <INSERT COMPANY NAME HERE> IS PROHIBITED.

**2X per assy		UNLESS OTHERWISE SPECIFIED:		NAME	DATE	TITLE:  Gusset		
		DIMENSIONS ARE IN INCHES TOLERANCES: FRACTIONAL ± ANGULAR: MACH ± BEND ± TWO PLACE DECIMAL ± THREE PLACE DECIMAL ±		DRAWN	BE			5/27/12
		INTERPRET GEOMETRIC TOLERANCING PER:		CHECKED				
		MATERIAL 0.25 HR Plate		ENG APPR.				
		FINISH		MFG APPR.				
NEXT ASSY	USED ON			Q.A.			SIZE	DWG. NO.
				COMMENTS:			<b>A</b>	
Hydraulic Tensioner		DO NOT SCALE DRAWING					SCALE: 1:1	SHEET 8 OF 10

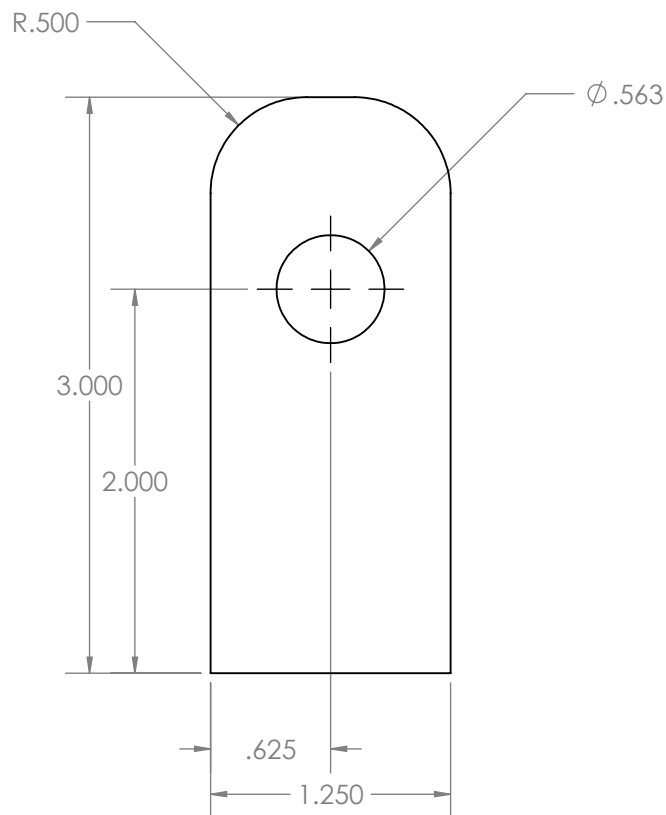

**1X per assy		UNLESS OTHERWISE SPECIFIED:		NAME	DATE		
		DIMENSIONS ARE IN INCHES		DRAWN	BE	5/27/12	TITLE:  Lower Cylinder Mount
		TOLERANCES:		CHECKED			
		FRACTIONAL ±		ENG APPR.			
		ANGULAR: MACH ± BEND ±		MFG APPR.			
		TWO PLACE DECIMAL ±		Q.A.			SIZE DWG. NO. <b>A</b>
		THREE PLACE DECIMAL ±		COMMENTS:			
		INTERPRET GEOMETRIC TOLERANCING PER:					SCALE: 1:1 SHEET 9 OF 10
		MATERIAL					
		0.50 HR Plate					
NEXT ASSY	USED ON	FINISH					
		DO NOT SCALE DRAWING					
	Hydraulic Tensioner						

**PROPRIETARY AND CONFIDENTIAL**  
 THE INFORMATION CONTAINED IN THIS DRAWING IS THE SOLE PROPERTY OF <INSERT COMPANY NAME HERE>. ANY REPRODUCTION IN PART OR AS A WHOLE WITHOUT THE WRITTEN PERMISSION OF <INSERT COMPANY NAME HERE> IS PROHIBITED.

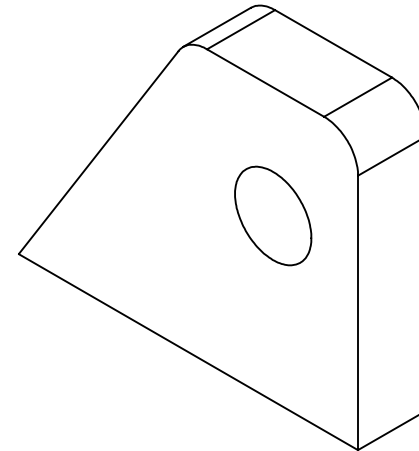
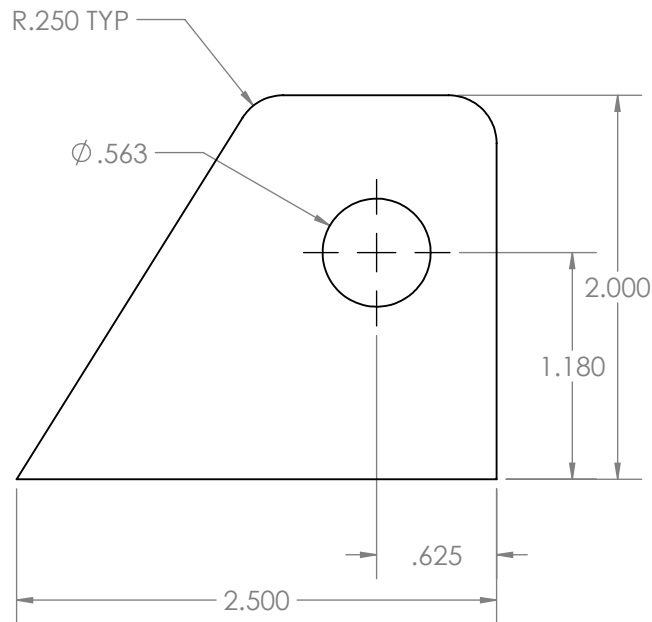

**1X per assy		UNLESS OTHERWISE SPECIFIED:		NAME	DATE	
		DIMENSIONS ARE IN INCHES	DRAWN	BE	5/27/12	TITLE:  Upper Cylinder Mount
		TOLERANCES:	CHECKED			
		FRACTIONAL ±	ENG APPR.			
		ANGULAR: MACH ± BEND ±	MFG APPR.			
		TWO PLACE DECIMAL ±	Q.A.			SIZE DWG. NO. <b>A</b>
		THREE PLACE DECIMAL ±	COMMENTS:			
		INTERPRET GEOMETRIC TOLERANCING PER:				SCALE: 1:1
		MATERIAL				SHEET 10 OF 10
		0.50 HR Plate				
		FINISH				
NEXT ASSY	USED ON					
	Hydraulic Tensioner	DO NOT SCALE DRAWING				

**PROPRIETARY AND CONFIDENTIAL**  
 THE INFORMATION CONTAINED IN THIS DRAWING IS THE SOLE PROPERTY OF <INSERT COMPANY NAME HERE>. ANY REPRODUCTION IN PART OR AS A WHOLE WITHOUT THE WRITTEN PERMISSION OF <INSERT COMPANY NAME HERE> IS PROHIBITED.

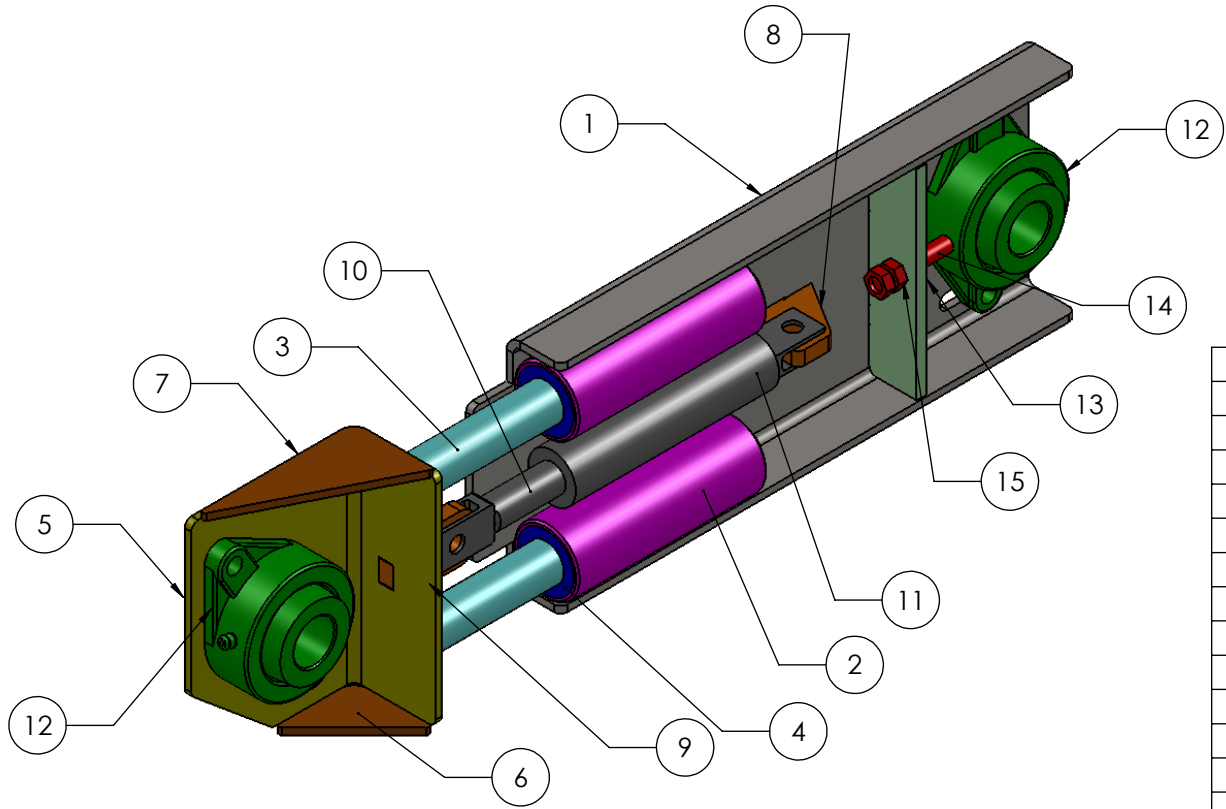

Part	Description
1	Upper Mount
2	Upper Slider Tube
3	Lower Slider Tube
4	UHMW Bushing
5	Lower Mount
6	Gusset 2
7	Gusset 1
8	Upper Cylinder Mount
9	Lower Cylinder Mount
10	Cylinder Lower
11	Cylinder Upper
12	Flange Bearing
13	Upper Adjuster
14	Adjuster Bolt
15	1/2 " Nut

**PROPRIETARY AND CONFIDENTIAL**  
 THE INFORMATION CONTAINED IN THIS DRAWING IS THE SOLE PROPERTY OF <INSERT COMPANY NAME HERE>. ANY REPRODUCTION IN PART OR AS A WHOLE WITHOUT THE WRITTEN PERMISSION OF <INSERT COMPANY NAME HERE> IS PROHIBITED.

		UNLESS OTHERWISE SPECIFIED:	NAME	DATE
		DIMENSIONS ARE IN INCHES	DRAWN	BE
		TOLERANCES:	CHECKED	5/27/12
		FRACTIONAL ±	ENG APPR.	
		ANGULAR: MACH ± BEND ±	MFG APPR.	
		TWO PLACE DECIMAL ±	Q.A.	
		THREE PLACE DECIMAL ±	COMMENTS:	
		INTERPRET GEOMETRIC TOLERANCING PER:		
		MATERIAL		
		FINISH		
NEXT ASSY	USED ON			

TITLE:	
Hydraulic Tensioner - R	
SIZE	DWG. NO.
<b>A</b>	
SCALE: 1:12	SHEET 1 OF 14

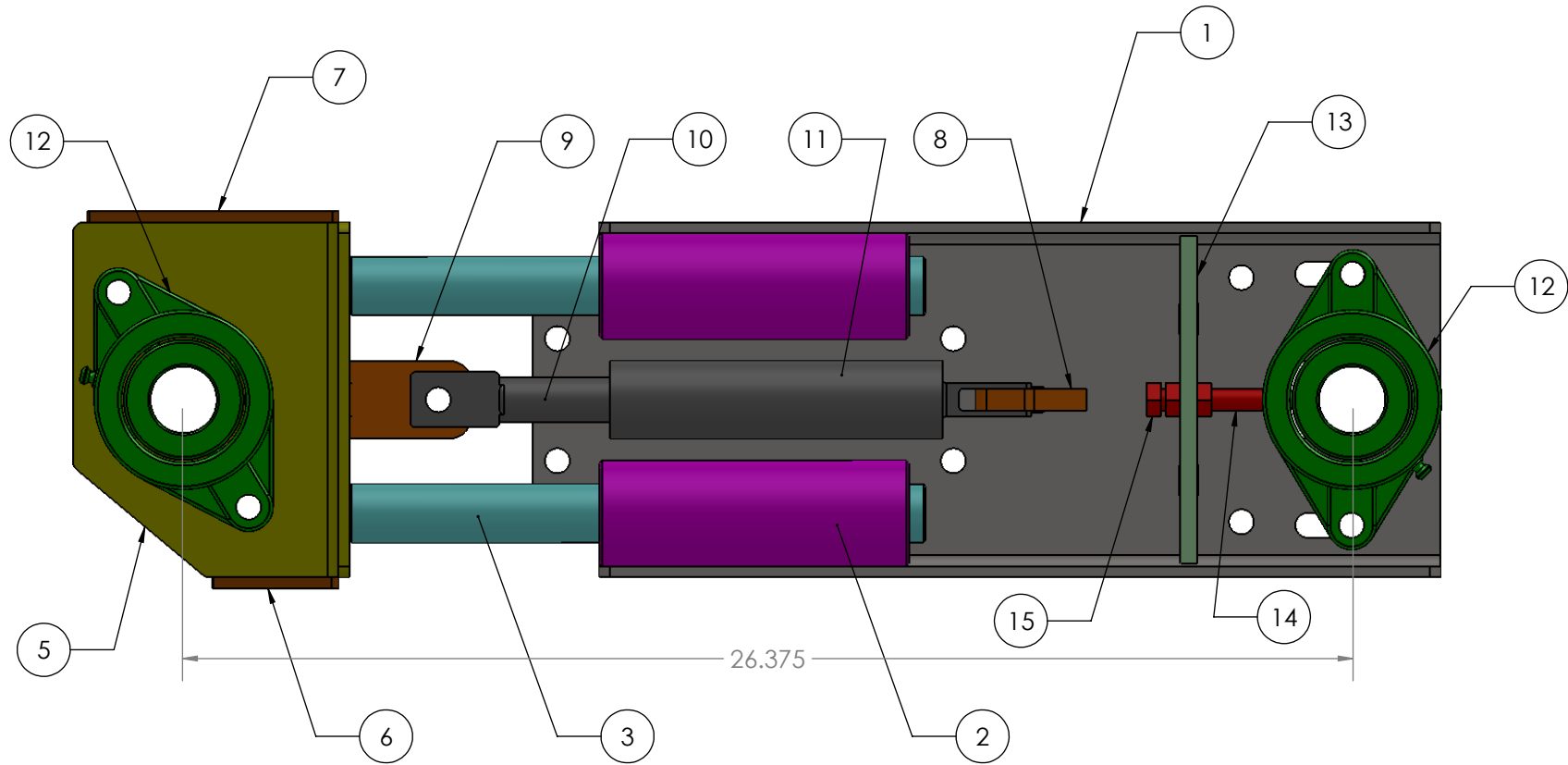

**PROPRIETARY AND CONFIDENTIAL**  
 THE INFORMATION CONTAINED IN THIS DRAWING IS THE SOLE PROPERTY OF <INSERT COMPANY NAME HERE>. ANY REPRODUCTION IN PART OR AS A WHOLE WITHOUT THE WRITTEN PERMISSION OF <INSERT COMPANY NAME HERE> IS PROHIBITED.

		UNLESS OTHERWISE SPECIFIED:		NAME	DATE	
		DIMENSIONS ARE IN INCHES		DRAWN	BE	5/27/12
		TOLERANCES:		CHECKED		TITLE:
		FRACTIONAL ±		ENG APPR.		Hydraulic Tensioner - R
		ANGULAR: MACH ± BEND ±		MFG APPR.		
		TWO PLACE DECIMAL ±		Q.A.		
		THREE PLACE DECIMAL ±		COMMENTS:		
		INTERPRET GEOMETRIC TOLERANCING PER:				SIZE DWG. NO.
		MATERIAL				<b>A</b>
NEXT ASSY	USED ON	FINISH				SCALE: 1:12 SHEET 2 OF 14
	Hydraulic Tensioner - R	DO NOT SCALE DRAWING				



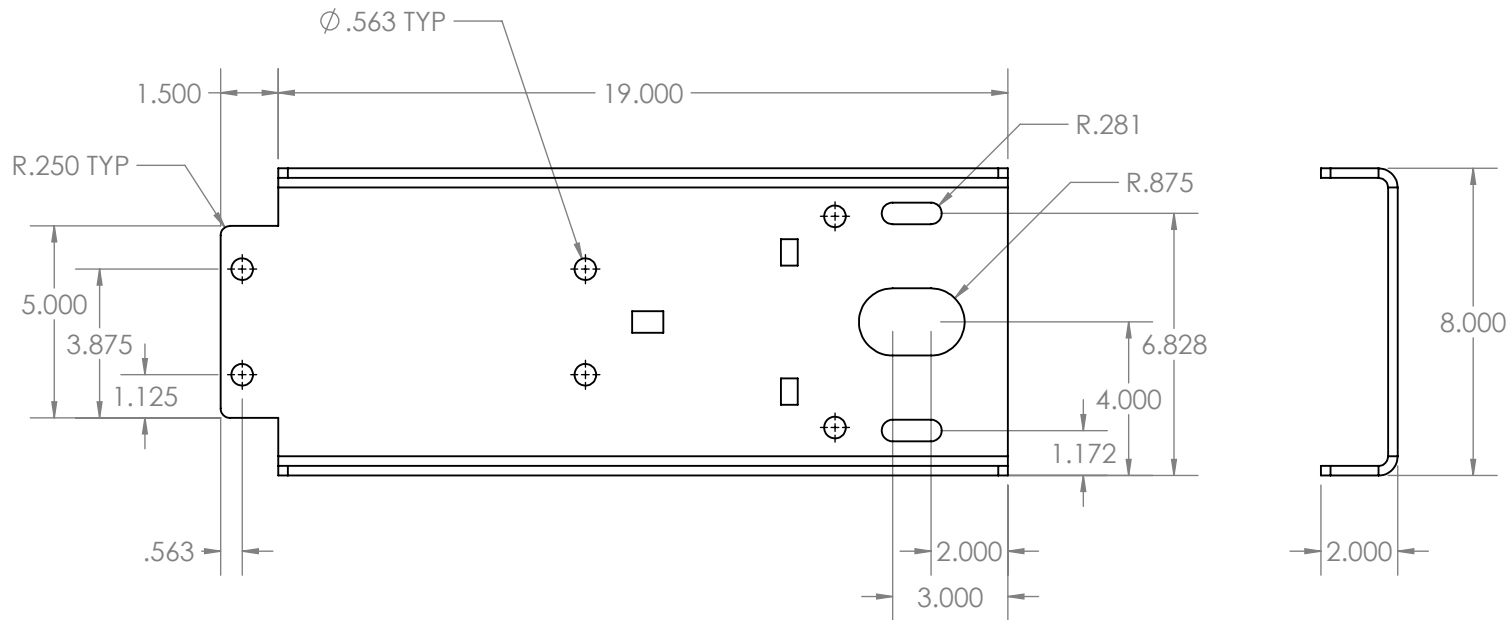

**1X per assy		UNLESS OTHERWISE SPECIFIED:		NAME	DATE	
		DIMENSIONS ARE IN INCHES	DRAWN	BE	5/27/12	TITLE:  Upper Mount - R
		TOLERANCES:	CHECKED			
		FRACTIONAL ±	ENG APPR.			
		ANGULAR: MACH ± BEND ±	MFG APPR.			
		TWO PLACE DECIMAL ±	Q.A.			SIZE DWG. NO. <b>A</b>
		THREE PLACE DECIMAL ±	COMMENTS:			
		INTERPRET GEOMETRIC TOLERANCING PER:				SCALE: 1:12
		MATERIAL				SHEET 3 OF 14
		0.25 HR Plate				
NEXT ASSY	USED ON	FINISH				
		DO NOT SCALE DRAWING				
	Hydraulic Tensioner - R					

**PROPRIETARY AND CONFIDENTIAL**  
 THE INFORMATION CONTAINED IN THIS DRAWING IS THE SOLE PROPERTY OF <INSERT COMPANY NAME HERE>. ANY REPRODUCTION IN PART OR AS A WHOLE WITHOUT THE WRITTEN PERMISSION OF <INSERT COMPANY NAME HERE> IS PROHIBITED.

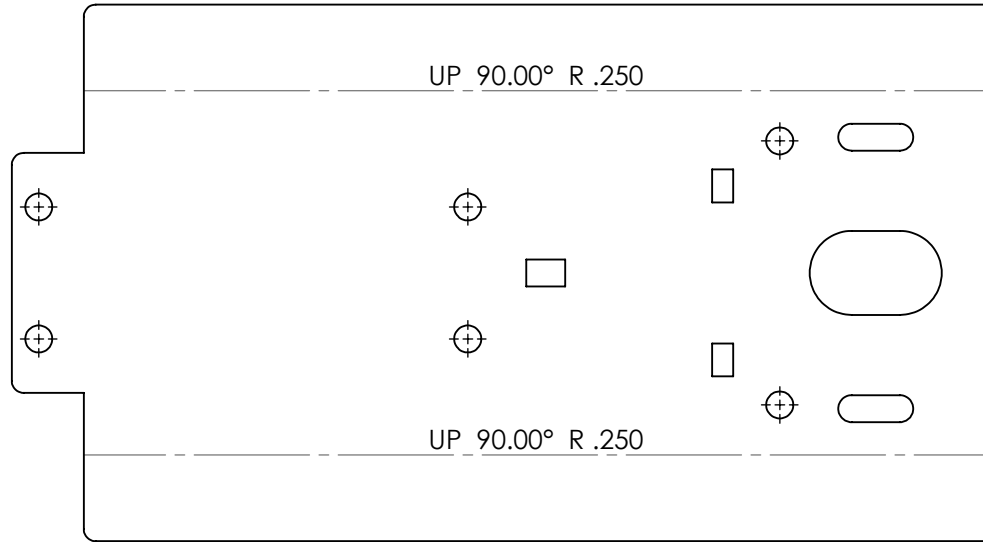

Flat Pattern View

**PROPRIETARY AND CONFIDENTIAL**  
 THE INFORMATION CONTAINED IN THIS DRAWING IS THE SOLE PROPERTY OF <INSERT COMPANY NAME HERE>. ANY REPRODUCTION IN PART OR AS A WHOLE WITHOUT THE WRITTEN PERMISSION OF <INSERT COMPANY NAME HERE> IS PROHIBITED.

		UNLESS OTHERWISE SPECIFIED:		NAME	DATE	
		DIMENSIONS ARE IN INCHES	DRAWN	BE	5/27/12	TITLE:  Upper Mount - R
		TOLERANCES:	CHECKED			
		FRACTIONAL ±	ENG APPR.			
		ANGULAR: MACH ± BEND ±	MFG APPR.			
		TWO PLACE DECIMAL ±	Q.A.			SIZE DWG. NO. <b>A</b>
		THREE PLACE DECIMAL ±	COMMENTS:			
		INTERPRET GEOMETRIC TOLERANCING PER:				SCALE: 1:12 SHEET 4 OF 14
		MATERIAL 0.25 HR Plate				
NEXT ASSY	USED ON	FINISH				
	Hydraulic Tensioner - R	DO NOT SCALE DRAWING				

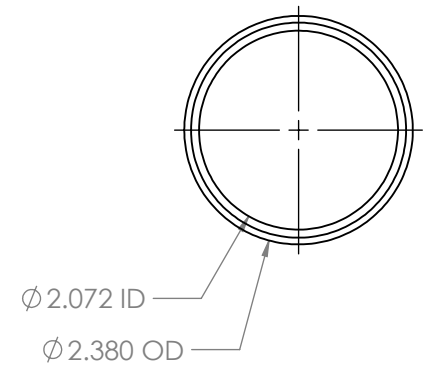
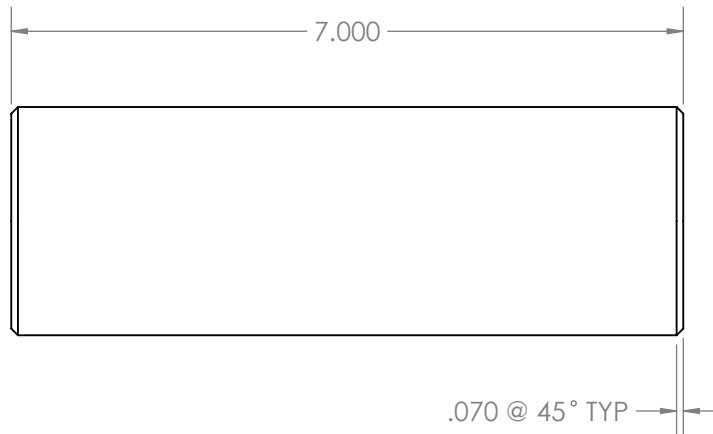

**PROPRIETARY AND CONFIDENTIAL**  
 THE INFORMATION CONTAINED IN THIS DRAWING IS THE SOLE PROPERTY OF <INSERT COMPANY NAME HERE>. ANY REPRODUCTION IN PART OR AS A WHOLE WITHOUT THE WRITTEN PERMISSION OF <INSERT COMPANY NAME HERE> IS PROHIBITED.

**2X per assy		UNLESS OTHERWISE SPECIFIED:		NAME	DATE	TITLE:  Upper Slider Tube - R
		DIMENSIONS ARE IN INCHES	DRAWN	BE	5/27/12	
		TOLERANCES: FRACTIONAL ±	CHECKED			
		ANGULAR: MACH ± BEND ±	ENG APPR.			
		TWO PLACE DECIMAL ±	MFG APPR.			SIZE DWG. NO. <b>A</b>
		THREE PLACE DECIMAL ±	Q.A.			
		INTERPRET GEOMETRIC TOLERANCING PER:	COMMENTS:			SCALE: 1:4 SHEET 5 OF 14
		MATERIAL 2 in sch 40				
NEXT ASSY	USED ON	FINISH				
	Hydraulic Tensioner - R	DO NOT SCALE DRAWING				

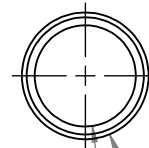
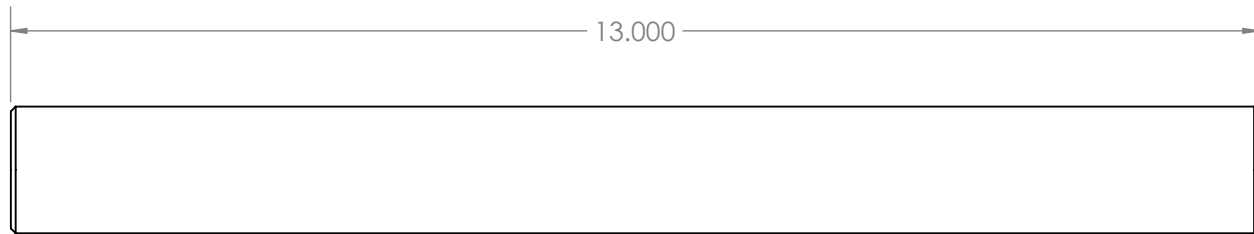

.050 @ 45° TYP

Ø 1.054 ID

Ø 1.320 OD

**PROPRIETARY AND CONFIDENTIAL**  
 THE INFORMATION CONTAINED IN THIS DRAWING IS THE SOLE PROPERTY OF <INSERT COMPANY NAME HERE>. ANY REPRODUCTION IN PART OR AS A WHOLE WITHOUT THE WRITTEN PERMISSION OF <INSERT COMPANY NAME HERE> IS PROHIBITED.

**2X per assy		UNLESS OTHERWISE SPECIFIED:		NAME	DATE	TITLE:  Lower Slider Tube - R
		DIMENSIONS ARE IN INCHES	DRAWN	BE	5/27/12	
		TOLERANCES: FRACTIONAL ±	CHECKED			
		ANGULAR: MACH ± BEND ±	ENG APPR.			
		TWO PLACE DECIMAL ±	MFG APPR.			SIZE DWG. NO. <b>A</b>
		THREE PLACE DECIMAL ±	Q.A.			
		INTERPRET GEOMETRIC TOLERANCING PER:	COMMENTS:			SCALE: 1:4
		MATERIAL 1 in sch 40				SHEET 6 OF 14
NEXT ASSY	USED ON	FINISH				
	Hydraulic Tensioner - R		DO NOT SCALE DRAWING			

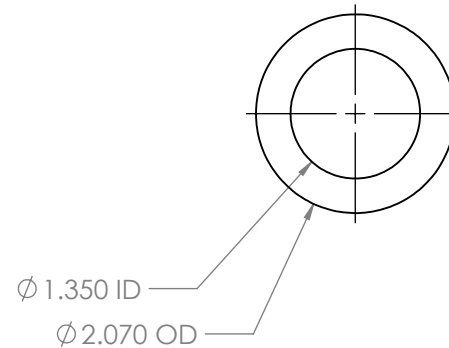
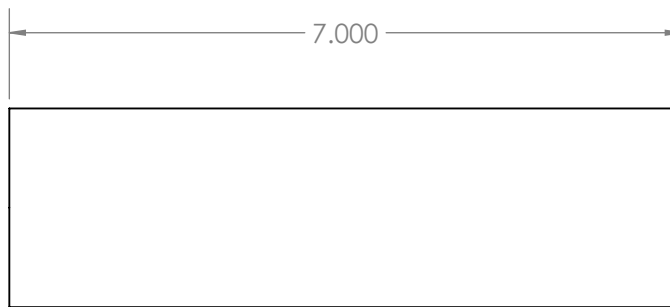

\*McMaster Carr Part # 8701K51 - Impact Resistant UHMW Polyethylene Rod  
2-1/4" Diameter, 2' length

\*\*Machine to dimensions noted

**PROPRIETARY AND CONFIDENTIAL**  
THE INFORMATION CONTAINED IN THIS DRAWING IS THE SOLE PROPERTY OF <INSERT COMPANY NAME HERE>. ANY REPRODUCTION IN PART OR AS A WHOLE WITHOUT THE WRITTEN PERMISSION OF <INSERT COMPANY NAME HERE> IS PROHIBITED.

**2X per assy		UNLESS OTHERWISE SPECIFIED:		NAME	DATE		
		DIMENSIONS ARE IN INCHES	DRAWN	BE	5/27/12	TITLE:  UHMW Bushing - R	
		TOLERANCES:	CHECKED				
		FRACTIONAL ±	ENG APPR.				
		ANGULAR: MACH ± BEND ±	MFG APPR.				
		TWO PLACE DECIMAL ±	Q.A.			SIZE	DWG. NO.
		THREE PLACE DECIMAL ±	COMMENTS:			<b>A</b>	
		INTERPRET GEOMETRIC TOLERANCING PER:				SCALE: 1:2	SHEET 7 OF 14
		MATERIAL					
		UHMW					
NEXT ASSY	USED ON	FINISH					
	Hydraulic Tensioner - R	DO NOT SCALE DRAWING					

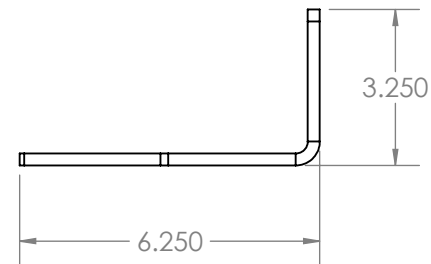
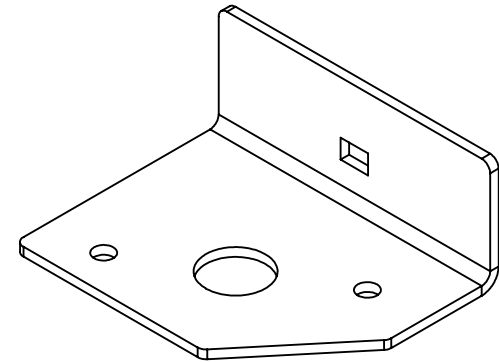
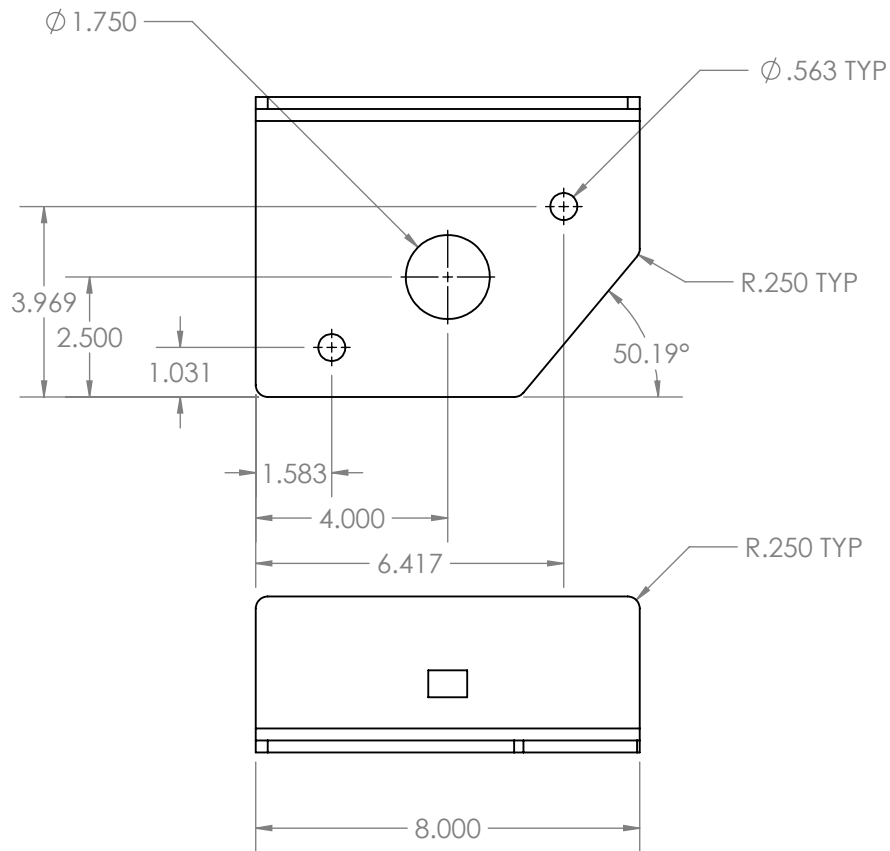

**PROPRIETARY AND CONFIDENTIAL**  
 THE INFORMATION CONTAINED IN THIS DRAWING IS THE SOLE PROPERTY OF <INSERT COMPANY NAME HERE>. ANY REPRODUCTION IN PART OR AS A WHOLE WITHOUT THE WRITTEN PERMISSION OF <INSERT COMPANY NAME HERE> IS PROHIBITED.

**1X per assy		UNLESS OTHERWISE SPECIFIED:	NAME	DATE	TITLE:  Lower Mount - R	
		DIMENSIONS ARE IN INCHES	DRAWN	BE		5/27/12
		TOLERANCES:	CHECKED			
		FRACTIONAL ±	ENG APPR.			
		ANGULAR: MACH ± BEND ±	MFG APPR.			
		TWO PLACE DECIMAL ±	Q.A.			
		THREE PLACE DECIMAL ±	COMMENTS:			
		INTERPRET GEOMETRIC TOLERANCING PER:				
		MATERIAL			SIZE DWG. NO.	
		0.25 HR Plate			<b>A</b>	
NEXT ASSY	USED ON	FINISH			SCALE: 1:4	
	Hydraulic Tensioner - R	DO NOT SCALE DRAWING			SHEET 8 OF 14	

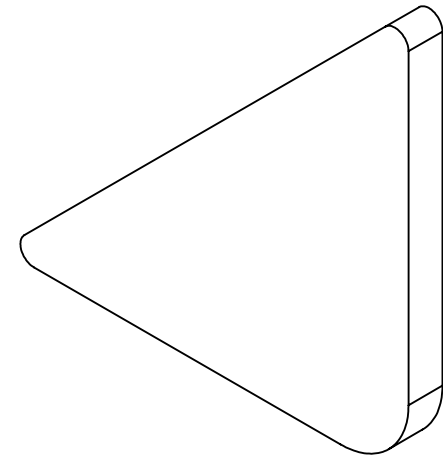
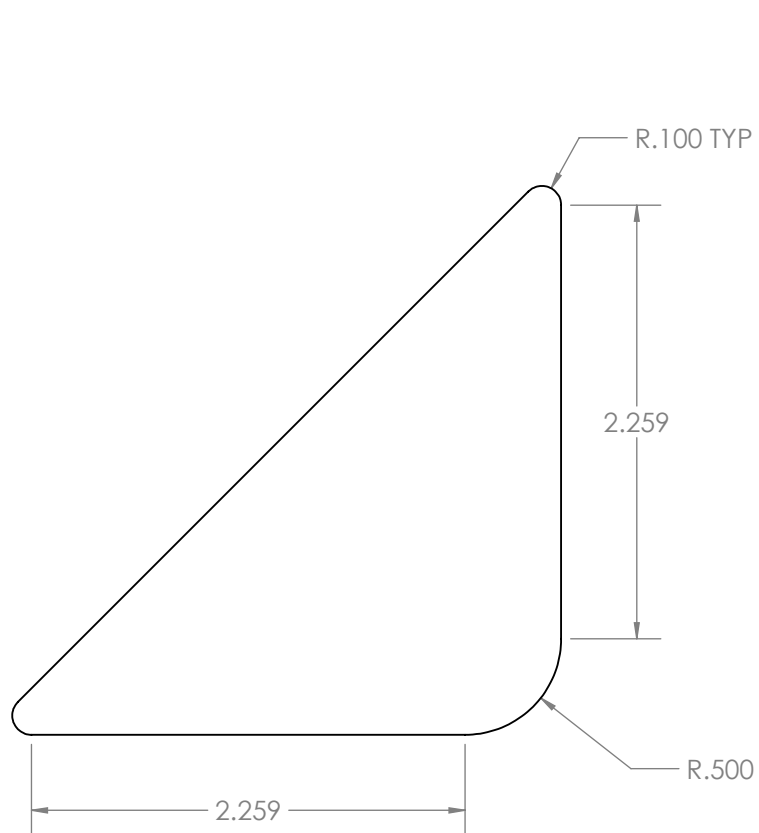

**PROPRIETARY AND CONFIDENTIAL**  
 THE INFORMATION CONTAINED IN THIS DRAWING IS THE SOLE PROPERTY OF <INSERT COMPANY NAME HERE>. ANY REPRODUCTION IN PART OR AS A WHOLE WITHOUT THE WRITTEN PERMISSION OF <INSERT COMPANY NAME HERE> IS PROHIBITED.

**1X per assy		UNLESS OTHERWISE SPECIFIED:		NAME	DATE		
		DIMENSIONS ARE IN INCHES	DRAWN	BE	5/27/12	TITLE:	
		TOLERANCES:	CHECKED			Gusset2	
		FRACTIONAL ±	ENG APPR.			SIZE DWG. NO.	
		ANGULAR: MACH ± BEND ±	MFG APPR.			A	
		TWO PLACE DECIMAL ±	Q.A.			SCALE: 1:1 SHEET 9 OF 14	
		THREE PLACE DECIMAL ±	COMMENTS:				
		INTERPRET GEOMETRIC TOLERANCING PER:					
		MATERIAL					
		0.25 HR Plate					
NEXT ASSY	USED ON	FINISH					
	Hydraulic Tensioner - R	DO NOT SCALE DRAWING					

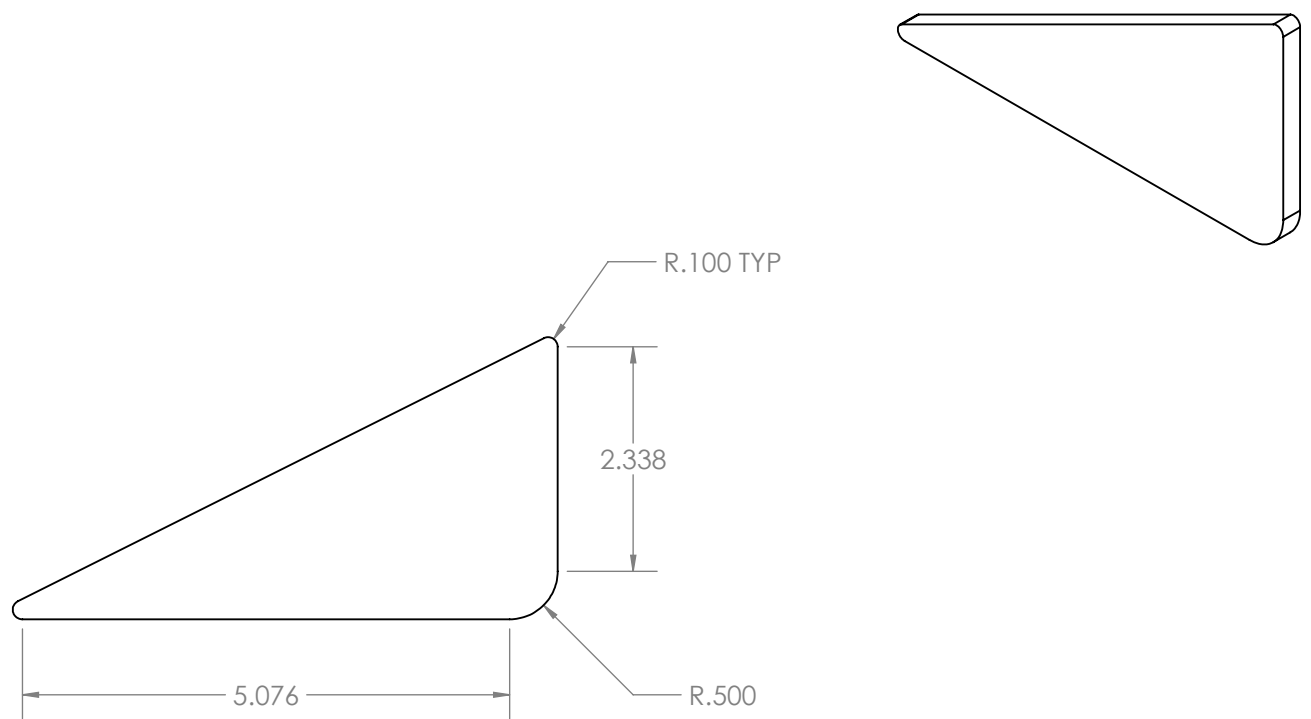

**PROPRIETARY AND CONFIDENTIAL**  
 THE INFORMATION CONTAINED IN THIS DRAWING IS THE SOLE PROPERTY OF <INSERT COMPANY NAME HERE>. ANY REPRODUCTION IN PART OR AS A WHOLE WITHOUT THE WRITTEN PERMISSION OF <INSERT COMPANY NAME HERE> IS PROHIBITED.

**1X per assy		UNLESS OTHERWISE SPECIFIED:		NAME	DATE		
		DIMENSIONS ARE IN INCHES	DRAWN	BE	5/27/12	TITLE:	
		TOLERANCES:	CHECKED			Gusset1	
		FRACTIONAL ±	ENG APPR.			SIZE DWG. NO.	
		ANGULAR: MACH ± BEND ±	MFG APPR.			A	
		TWO PLACE DECIMAL ±	Q.A.			SCALE: 1:1 SHEET 10 OF 14	
		THREE PLACE DECIMAL ±	COMMENTS:				
		INTERPRET GEOMETRIC TOLERANCING PER:					
		MATERIAL	0.25 HR Plate				
NEXT ASSY	USED ON	FINISH					
Hydraulic Tensioner - R		DO NOT SCALE DRAWING					



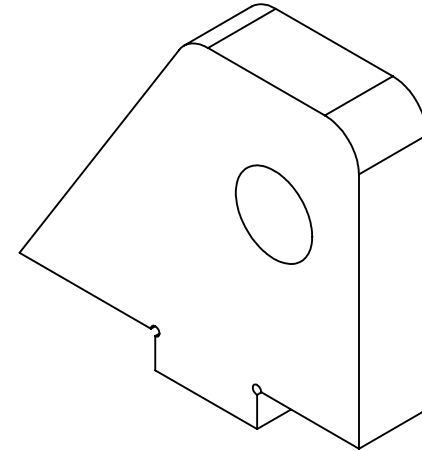
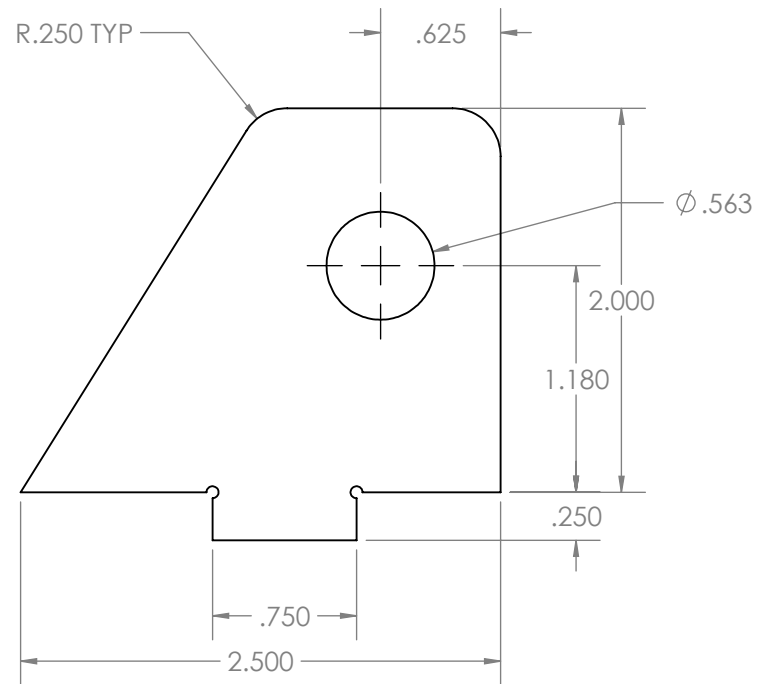

**PROPRIETARY AND CONFIDENTIAL**  
 THE INFORMATION CONTAINED IN THIS DRAWING IS THE SOLE PROPERTY OF <INSERT COMPANY NAME HERE>. ANY REPRODUCTION IN PART OR AS A WHOLE WITHOUT THE WRITTEN PERMISSION OF <INSERT COMPANY NAME HERE> IS PROHIBITED.

**1X per assy		UNLESS OTHERWISE SPECIFIED:		NAME	DATE	
		DIMENSIONS ARE IN INCHES	DRAWN	BE	5/27/12	TITLE: Upper Cylinder Mount - R
		TOLERANCES:	CHECKED			
		FRACTIONAL ±	ENG APPR.			
		ANGULAR: MACH ± BEND ±	MFG APPR.			
		TWO PLACE DECIMAL ±	Q.A.			SIZE DWG. NO. <b>A</b>
		THREE PLACE DECIMAL ±	COMMENTS:			
		INTERPRET GEOMETRIC TOLERANCING PER:				SCALE: 1:2 SHEET 11 OF 14
		MATERIAL 0.50 HR Plate				
NEXT ASSY	USED ON	FINISH				
	Hydraulic Tensioner - R	DO NOT SCALE DRAWING				

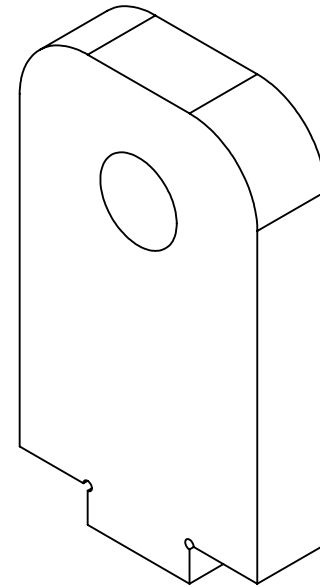
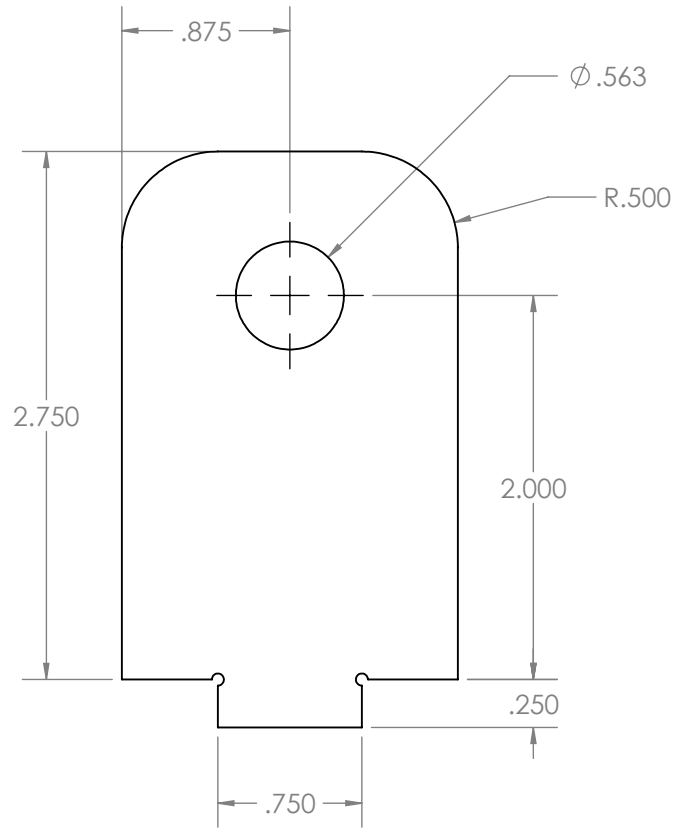

**PROPRIETARY AND CONFIDENTIAL**  
 THE INFORMATION CONTAINED IN THIS DRAWING IS THE SOLE PROPERTY OF <INSERT COMPANY NAME HERE>. ANY REPRODUCTION IN PART OR AS A WHOLE WITHOUT THE WRITTEN PERMISSION OF <INSERT COMPANY NAME HERE> IS PROHIBITED.

**1X per assy		UNLESS OTHERWISE SPECIFIED:		NAME	DATE	TITLE:  Lower Cylinder Mount - R
		DIMENSIONS ARE IN INCHES	DRAWN	BE	5/27/12	
		TOLERANCES: FRACTIONAL ±	CHECKED			
		ANGULAR: MACH ± BEND ±	ENG APPR.			
		TWO PLACE DECIMAL ±	MFG APPR.			SIZE DWG. NO. <b>A</b>
		THREE PLACE DECIMAL ±	Q.A.			
		INTERPRET GEOMETRIC TOLERANCING PER:	COMMENTS:			SCALE: 1:1 SHEET 12 OF 14
NEXT ASSY	USED ON	MATERIAL 0.50 HR Plate				
		FINISH				
	Hydraulic Tensioner - R	DO NOT SCALE DRAWING				

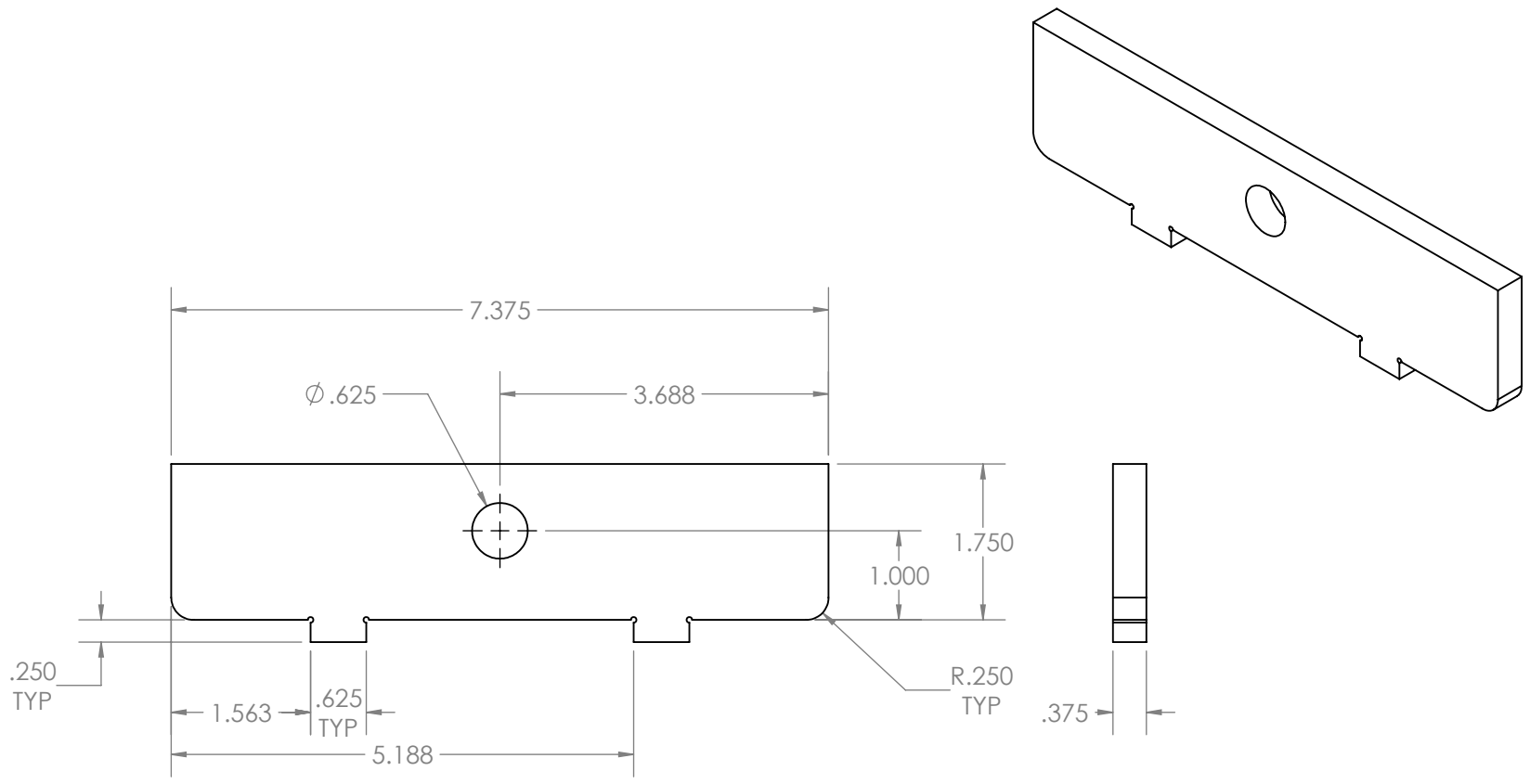

**PROPRIETARY AND CONFIDENTIAL**  
 THE INFORMATION CONTAINED IN THIS DRAWING IS THE SOLE PROPERTY OF <INSERT COMPANY NAME HERE>. ANY REPRODUCTION IN PART OR AS A WHOLE WITHOUT THE WRITTEN PERMISSION OF <INSERT COMPANY NAME HERE> IS PROHIBITED.

**1X per assy		UNLESS OTHERWISE SPECIFIED:		NAME	DATE	TITLE:  Upper Adjuster Plate
		DIMENSIONS ARE IN INCHES	DRAWN	BE	5/27/12	
		TOLERANCES:	CHECKED			
		FRACTIONAL ±	ENG APPR.			
		ANGULAR: MACH ± BEND ±	MFG APPR.			SIZE DWG. NO. <b>A</b>
		TWO PLACE DECIMAL ±	Q.A.			
		THREE PLACE DECIMAL ±	COMMENTS:			SCALE: 1:2 SHEET 13 OF 14
		INTERPRET GEOMETRIC TOLERANCING PER:				
NEXT ASSY	USED ON	MATERIAL 0.375 HR Plate				
		FINISH				
	Hydraulic Tensioner - R	DO NOT SCALE DRAWING				

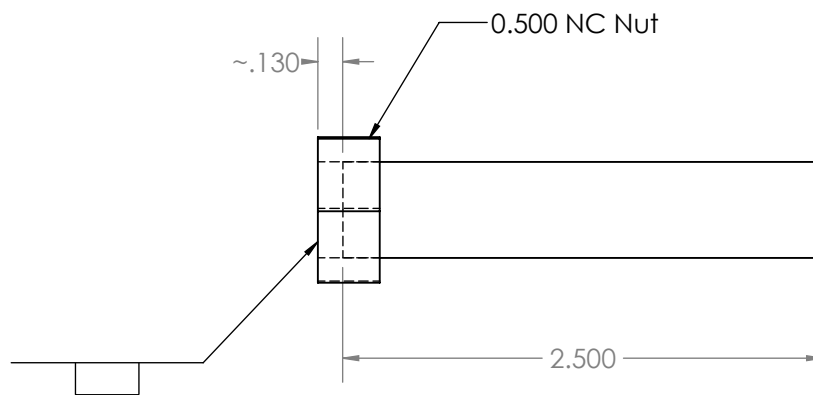

**1X per assy		UNLESS OTHERWISE SPECIFIED:		NAME	DATE		
		DIMENSIONS ARE IN INCHES	DRAWN	BE	5/27/12	TITLE:	
		TOLERANCES:	CHECKED			Adjuster Bolt	
		FRACTIONAL ±	ENG APPR.				
		ANGULAR: MACH ± BEND ±	MFG APPR.				
		TWO PLACE DECIMAL ±	Q.A.				
		THREE PLACE DECIMAL ±	COMMENTS:				
		INTERPRET GEOMETRIC TOLERANCING PER:				SIZE	DWG. NO.
		MATERIAL				<b>A</b>	
		0.500 NC Threaded Rod				SCALE: 1:12	SHEET 14 OF 14
		FINISH					
NEXT ASSY	USED ON	DO NOT SCALE DRAWING					
	Hydraulic Tensioner - R						

**PROPRIETARY AND CONFIDENTIAL**  
 THE INFORMATION CONTAINED IN THIS DRAWING IS THE SOLE PROPERTY OF <INSERT COMPANY NAME HERE>. ANY REPRODUCTION IN PART OR AS A WHOLE WITHOUT THE WRITTEN PERMISSION OF <INSERT COMPANY NAME HERE> IS PROHIBITED.

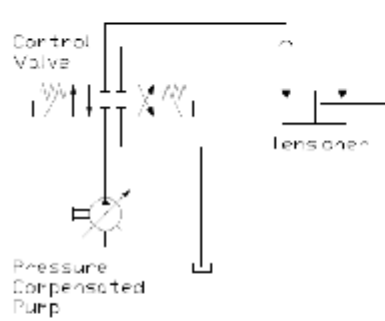

Hydraulic Circuit as Tested

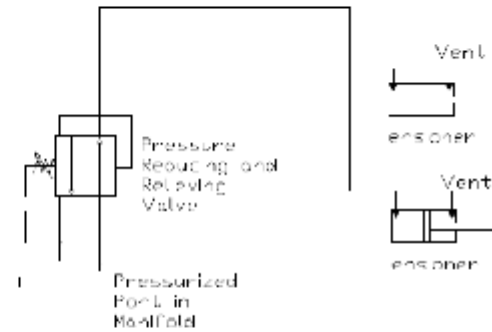

Proposed Circuit as Addition to Harvesters Hydraulics

Pressure Reducing and Relieving Valve: A pressure reducing/relieving valve is used to maintain a constant reduced pressure in a circuit regardless of pressure fluctuations. If the pressure in the secondary circuit increases beyond the set point, the valve internally reliefs back to the tank port. This type of valve should be very effective as a pressure control valve for the tensioner system.

**PROPRIETARY AND CONFIDENTIAL**  
 THE INFORMATION CONTAINED IN THIS DRAWING IS THE SOLE PROPERTY OF <INSERT COMPANY NAME HERE>. ANY REPRODUCTION IN PART OR AS A WHOLE WITHOUT THE WRITTEN PERMISSION OF <INSERT COMPANY NAME HERE> IS PROHIBITED.

		UNLESS OTHERWISE SPECIFIED:		NAME	DATE		
		DIMENSIONS ARE IN INCHES	DRAWN	BE	5/27/12	TITLE:  Hydraulic Circuit	
		TOLERANCES:	CHECKED				
		FRACTIONAL ±	ENG APPR.				
		ANGULAR: MACH ± BEND ±	MFG APPR.				
		TWO PLACE DECIMAL ±	Q.A.			SIZE	DWG. NO.
		THREE PLACE DECIMAL ±	COMMENTS:			<b>A</b>	
		INTERPRET GEOMETRIC TOLERANCING PER:				SCALE: 1:1	SHEET 1 OF 1
		MATERIAL					
NEXT ASSY	USED ON	FINISH					
Hydraulic Tensioner		DO NOT SCALE DRAWING					